

SERVICE INSTRUCTION

AEROBELL SHAPING AIR RINGS

Thread Shaping Air Ring [78298-00] into Shaping Air Cap [78297-00] snug until stopped using tool [79005-00]. Tighten fully to 89 lbs•in torque. When installed, surface "B" is to be flush or protruding slightly (up to .007 inches) to surface "A".

Before installing the shaping air cap assembly onto the Manifold Assembly [78300-00], apply a small amount of petroleum jelly onto the manifold threads and the o-ring. This is to stop metal to metal threads from galling.

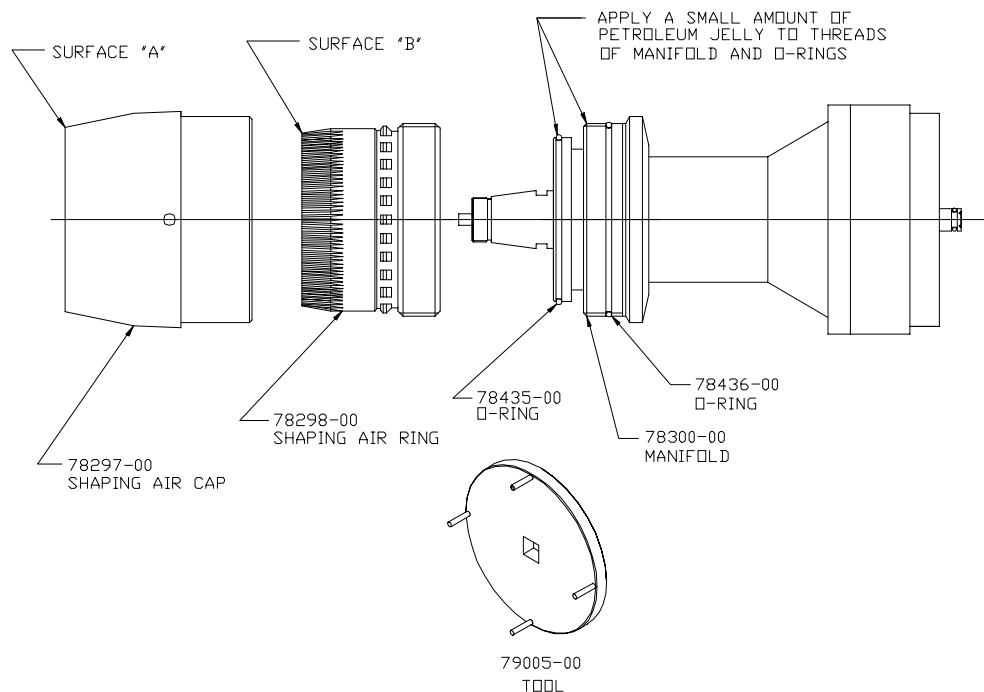



Electrostatic Systems

An Illinois Tool Works Company



Industrial Systems

ITW Ransburg Electrostatic Systems

320 Phillips Avenue

Toledo, OH 43612

Website: www.itwransburg.com

E-mail: marketing@itwransburg.com

Telephone: 419/470-2000

Fax: 419/470-2270

Form No. SI-02-02.2
© 2003 Illinois Tool Works Inc.

Litho in U.S.A.

2/03 - 50

Trademarks indicated with ® are registered with the United States Patent and Trademark Office by ITW Ransburg. Patents issued and pending in the United States Patent and Trademark Office.

All rights reserved. Models and specifications subject to change without notice.
