

---

## PAINT, HIGH VOLTAGE & SCI TEST EQUIPMENT

---



- 76652-01 HIGH VOLTAGE PROBE**
  - 76652-02 SPRAYABILITY/SCI METER**
  - 76652-03 PAINT RESISTIVITY METER**
  - 76652-04 DELUXE KIT**
  - A11757-00 HIGH VOLTAGE PROBE ADAPTER**
- 

**IMPORTANT:** Before using this equipment, carefully read **SAFETY PRECAUTIONS**, starting on page 1, and all instructions in this manual. Keep this Service Manual for future reference.

Service Manual Price: \$30.00 (U.S.)

**NOTE:** This manual has been changed from revision **TE-98-01.4** to revision **TE-98-01.5**.  
Reasons for this change are noted under “Manual Change Summary” inside the back cover of this manual.

---

# CONTENTS

---

	<b>PAGE</b>
<b>SAFETY:</b>	<b>1 - 3</b>
SAFETY PRECAUTIONS.....	1
HAZARDS/SAFEGUARDS.....	2-3
<b>TEST EQUIPMENT:</b>	<b>5-17</b>
MULTI-FUNCTION ELECTROSTATIC METER.....	5-6
SPRAYABILITY, SCI, AND RESISTANCE MEASUREMENT KIT.....	7-12
PAINT RESISTANCE MEASUREMENT KIT.....	12-13
HIGH VOLTAGE MEASUREMENT KIT.....	14-16
GENERAL MAINTENANCE.....	17
<b>WARRANTY POLICIES:</b>	<b>19</b>
LIMITED WARRANTY.....	19
<b>APPENDIX:</b>	<b>20-23</b>
PAINT AND SOLVENT SPECIFICATIONS.....	20
VISCOSITY CONVERSION CHART.....	21-22
VOLUMETRIC CONTENT OF HOSE OR TUBE.....	23

# SAFETY

## SAFETY PRECAUTIONS

Before operating, maintaining or servicing any ITW Ransburg coating system, read and understand all of the technical and safety literature for your ITW Ransburg products. This manual contains information that is important for you to know and understand. This information relates to **USER SAFETY** and **PREVENTING EQUIPMENT PROBLEMS**. To help you recognize this information, we use the following symbols. Please pay particular attention to these sections.

**A WARNING!** states information to alert you to a situation that might cause serious injury if instructions are not followed.

**A CAUTION!** states information that tells how to prevent damage to equipment or how to avoid a situation that might cause minor injury.

**A NOTE** is information relevant to the procedure in progress.

While this manual lists standard specifications and service procedures, some minor deviations may be found between this literature and your equipment. Differences in local codes and plant requirements, material delivery requirements, etc., make such variations inevitable. Compare this manual with your system installation drawings and appropriate ITW Ransburg equipment manuals to reconcile such differences.

Careful study and continued use of this manual will provide a better understanding of the equipment and process, resulting in more efficient operation, longer trouble-free service and faster, easier troubleshooting. If you do not have the manuals and safety literature for your Ransburg system, contact your local ITW Ransburg representative or ITW Ransburg.



### WARNING

- ▶ The user **MUST** read and be familiar with the Safety Section in this manual and the ITW Ransburg safety literature therein identified.
- ▶ This manual **MUST** be read and thoroughly understood by **ALL** personnel who operate, clean or maintain this equipment! Special care should be taken to ensure that the **WARNINGS** and safety requirements for operating and servicing the equipment are followed. The user should be aware of and adhere to **ALL** local building and fire codes and ordinances as well as **NFPA-33 SAFETY STANDARD**, prior to installing, operating, and/or servicing this equipment.

### WARNING

- ▶ The hazards shown on the following page may occur during the normal use of this equipment. Please read the hazard chart beginning on page 2.

<p><b>AREA</b> Tells where hazards may occur.</p>	<p><b>HAZARD</b> Tells what the hazard is.</p>	<p><b>SAFEGUARDS</b> Tells how to avoid the hazard.</p>
<p><b>Spray Area</b></p> 	<p>Electrostatic Arcing</p>	<p>Never operate the spray gun without properly grounding the following:</p> <p>A. Operators</p> <p>Operators must be grounded. Rubber soled insulating shoes should not be worn. Grounding leg straps may be used.</p> <p>Operators must maintain contact with the handle of the gun. If work gloves are used, the palm section should be cut out.</p> <p>Operators must remove from themselves all metal objects that are not grounded.</p> <p><b>NOTE: REFER TO NFPA-33 REGARDING OPERATOR GROUNDING</b></p> <p>B. Parts being sprayed. Resistance between the part and a grounded conveyor must not exceed 1 megohm.</p> <p>C. Every metal and conductive object in the spray area. This includes the booth, parts hangers, fire extinguishers, conductive flooring, etc.</p> <p>Grounded conductive flooring must be provided in the spray area.</p> <p>Turn off voltage at the power supply before flushing out, cleaning, or removing any parts from the gun.</p> <p>Provide proper protection for waterborne supply systems.</p> <p>Never install a spray gun into a fluid system using an isolated solvent supply.</p> <p>Always discharge Waterborne system capacitance prior to servicing.</p> <p>Do not touch gun electrode while gun is energized.</p>

<b>AREA</b> Tells where hazards may occur.	<b>HAZARD</b> Tells what the hazard is.	<b>SAFEGUARDS</b> Tells how to avoid the hazard.
<b>Toxic Substances</b>  	Certain materials may be harmful if inhaled or if there is contact with the skin.	Follow the requirements of the Material Safety Data Sheet supplied by your coating material manufacturer.  Adequate exhaust must be provided to keep the air free of accumulations of toxic materials.  Use a mask or respirator whenever there is a chance of inhaling sprayed materials. The mask must be compatible with the material being sprayed and its concentration. Equipment must be as prescribed by an industrial hygienist or safety expert, and be NIOSH approved.
<b>General Use and Maintenance</b>  	Improper operation or maintenance may create a hazard.  Personnel must be properly trained in the use of this equipment.	Personnel must be given training in accordance with the requirements of NFPA-33.  Instructions and safety precautions must be read and understood prior to using this equipment.  Comply with appropriate local, state, and national codes governing ventilation, fire protection, operation, maintenance, and housekeeping. Reference OSHA, NFPA-33, and your insurance company requirements.

**NOTES**

## MULTI-FUNCTION ELECTROSTATIC METER

The ITW Ransburg *Multi-Function Electrostatic Spray Meter* uses one meter to serve multi-functions in electrostatic spray finishing. The meter can be used to measure conductivity, paint resistance, short circuit current, resistance, and high voltage. The meter is available in individual kits focused on each function or a deluxe kit, which includes accessories to perform all the functions listed above.

The ITW Ransburg Multi-Function Electrostatic Spray Meter is powered by a single 9V alkaline battery. The solid state circuitry only requires 9V input to power the meter display and condition all the signals from the accessory items.

Part #	Description
76652-01	Kit for measuring high voltage. Includes 76634-00 Multi-Function Meter and 76667 High Voltage Probe Assembly.
76652-02	Kit for measuring short circuit current (SCI), resistance and sprayability. Includes 76634-00 Multi-Function Meter and 76664-00 Test Lead Assembly.
76652-03	Kit for measuring paint resistivity. Includes 76634-00 Multi-Function Meter and 7922-00 Paint Probe Assembly.
76652-04	Deluxe Kit Performs all functions listed above. Includes 76634-00 Multi-Function Meter, 7922-00 Paint Probe Assembly, 76664-00 Test Lead Assembly, and 76667-00 High Voltage Probe Assembly.
A11757-00	High Voltage Probe Adapter Adapter to measure the voltage coming from an individual probe (electrode) assembly on RMA-303 Indirect Charge Robot Mounted Rotary Atomizer (A11600, A11300), Aerobell 2.5 Indirect Charge (A10924), and Aerobell II Indirect Charge (77603).

### Meter Scale Ranges:\*

kV: 0 to  $\pm 199.9$  kVDC

$\mu$ A: 0 to  $\pm 1999$   $\mu$ A

k $\Omega$ : 1 to 1999 k $\Omega$  (.001 to 1.999 M $\Omega$ )

M $\Omega$ : 00.1M $\Omega$  to 199.9 M $\Omega$

G $\Omega$ : .1G $\Omega$  to 19.99 G $\Omega$

\* **Note:** For readings below 2 M $\Omega$ , more resolution can be obtained by using the k $\Omega$  scale.

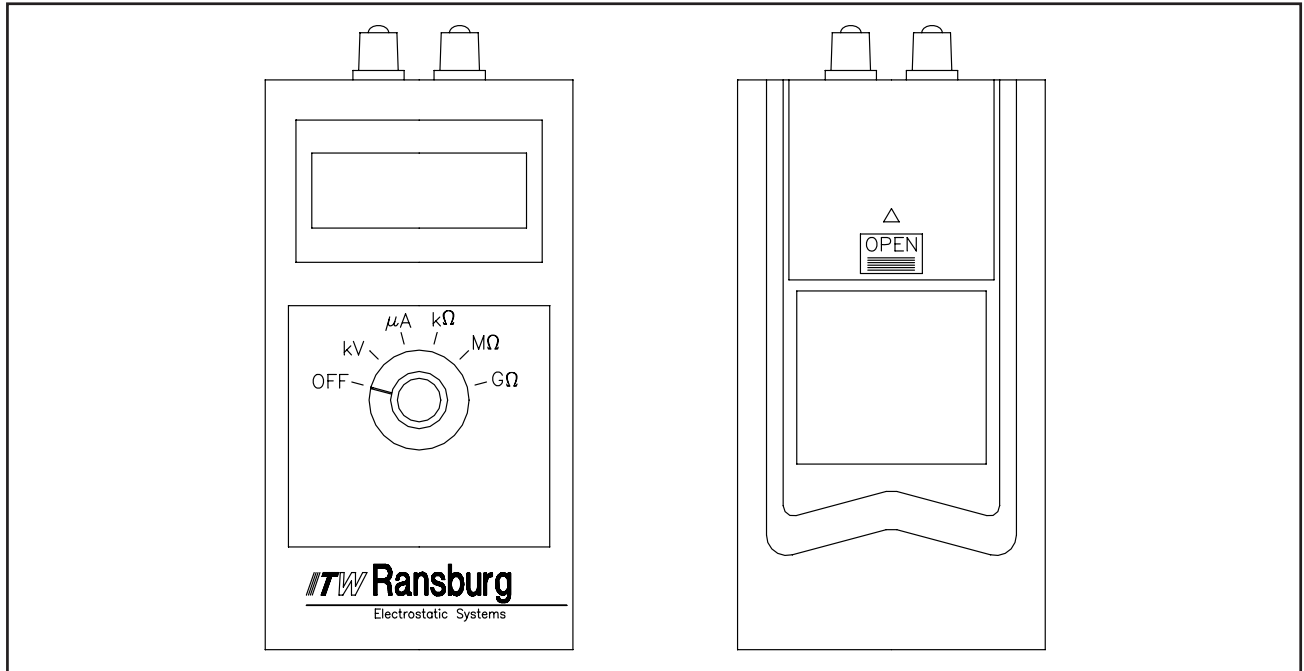

**Figure 1A: Multi-Function Meter**

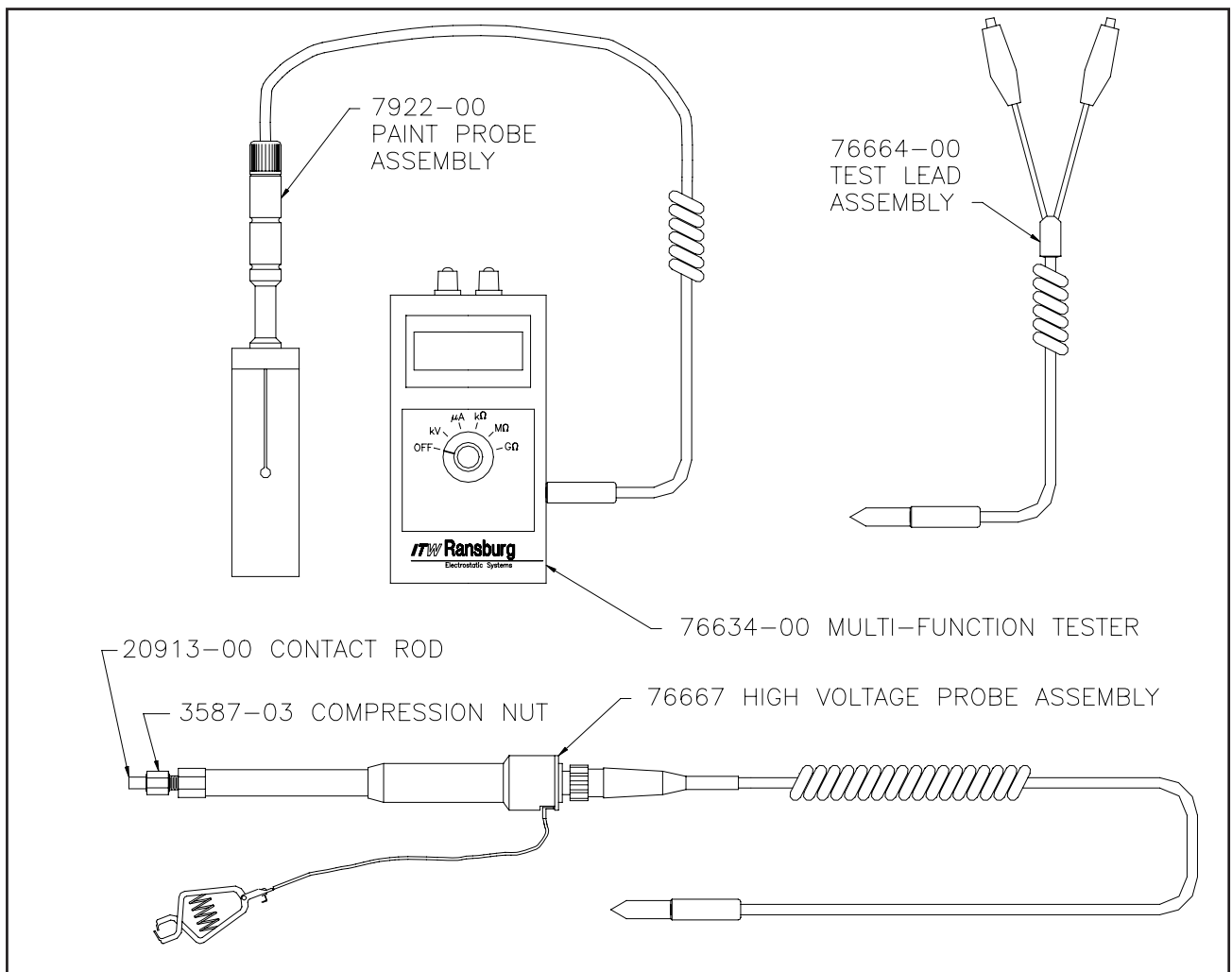

**Figure 1B: Multi-Function Meter Kit Parts**

## SPRAYABILITY, SCI, AND RESISTANCE MEASUREMENT KIT

### Sprayability

The **Sprayability Meter** measures whether materials normally considered being electrically non-conductive could be electrostatically sprayed or whether they need to be treated with solutions to make the surface conductive. The meter measures the surface resistance and indicates the degree of sprayability in MΩ or GΩ. The target being sprayed must be low enough in resistance to dissipate the electrostatic charge. In some cases the internal resistance of a target is lower than the surface resistance. This might allow a target that does not have a suitable surface resistance reading to be coated electrostatically without additional surface preparation. An example of this is certain types of wood which on the surface are not conductive but due to moisture content (12%-13%) may be sprayable.

Since many non-conductive products must be pre-treated with a conductive solution to make them sprayable, the ITW Ransburg Multi-Function Electrostatic Spray Meter is useful to monitor and maintain consistency in that application, once a suitable reading is determined.



### CAUTION

- Ensure that meter's scale is properly set for the function in which it is being used. Damage to equipment may result if improperly set.

### Operation

1. Set the meter dial to the MΩ or GΩ scale (see Figure 2). Check the meter calibration by touching the metallic end of the two (2) probes on the meter to the stripped bare ends of a single 12" long wire (see Figure 2). (If desired the continuity of the wire may be verified by using a Volt-Ohm meter). If the meter reads zero, the meter is in calibration. If it does not read zero, verify the continuity of the wire

and re-perform the check. If the meter still does not read zero, consult the factory for repair of the meter.

2. With the metallic part of the meter probes pressed firmly and perpendicular against the surface of the article to be tested, the meter automatically reads the resistance of the part. Table 1 lists the readings from an 8333-00 meter and compares it to the readings of the Multi-Function Meter.

### Meter Readings

**0Ω to 1.0GΩ** - The article is suitable for spraying using the electrostatic process.

**1.0GΩ to 1.5GΩ** - The article is questionable for spraying using the electrostatic process. In such cases, paint a trial sample article to determine if a conductive primer or conductive solution for the part surface is required.

**1.5GΩ to Infinity** - The article is **NOT** suitable for spraying. A conductive primer or conductive solution is required to treat the surface of the part.

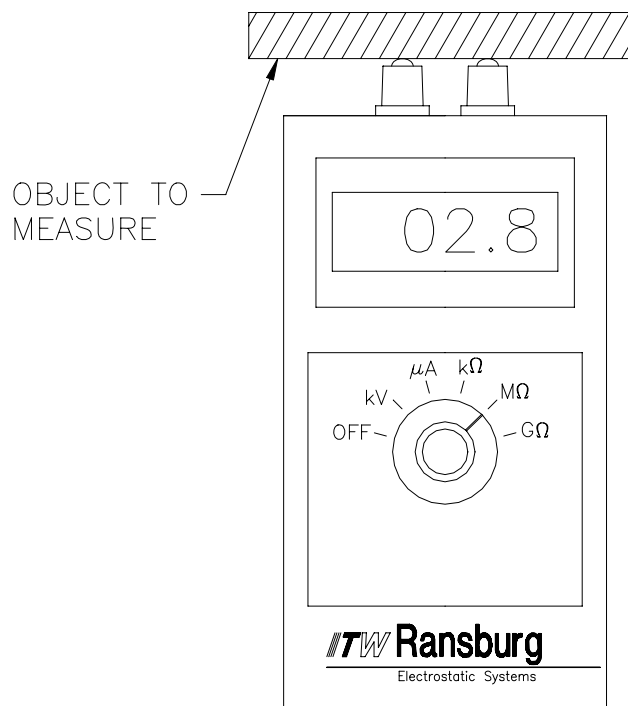

Figure 2: Sprayability Test Meter

<b>New 76652-01 Multi-Function Meter Reading</b>	<b>8333-00 Sprayability Meter Reading</b>	<b>Spray Condition</b>
1 MΩ	155	Suitable
2 MΩ	150	Suitable
3 MΩ	147	Suitable
4 MΩ	145	Suitable
14 MΩ	140	Suitable
60 MΩ	135	Suitable
190 MΩ or .1 GΩ	130	Suitable
320 MΩ or .3 GΩ	125	Suitable
410 MΩ or .4 GΩ	120	Suitable
500 MΩ or .5 GΩ	115	Suitable
600 MΩ or .6 GΩ	110	Suitable
760 MΩ or .7 GΩ	105	Suitable
1020 MΩ or 1.0 GΩ	100	Suitable
1.1 GΩ	98	Test Sample Part
1.3 GΩ	95	Test Sample Part
1.5 GΩ	90	Test Sample Part
2.0 GΩ to Infinity	85 or less	Requires Surface Prep

**Table 1: Comparison to 8333-00 Sprayability Meter with New Multi-Function Meter**

## Resistance/Testing

### Target/Product Ground

The ITW Ransburg Multi-Function Meter may be used to measure approximate resistance in  $k\Omega$ ,  $M\Omega$ , or  $G\Omega$ . Applications for the meter range from measuring the resistance of a 70430-XX resistor to measuring the resistance of a target to ground.

#### CAUTION

- ▶ Ensure that meter's scale is properly set for the function in which it is being used. Damage to equipment may result if improperly set.

#### NOTE

- ▶ When using the Multi-Function Meter test leads to measure resistance or current, ensure that the sprayability probes do not come into contact with any surface or the meter readings may be altered.

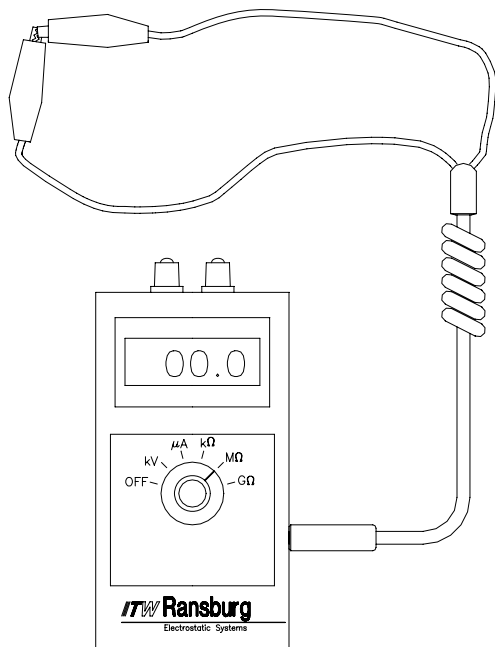

Figure 3: Calibration Check Resistance

### Operation

1. Set the meter dial to the  $M\Omega$  scale (see Figure 3). Plug the probe with two (2) alligator clamp leads into the side of the meter. Check the meter calibration by touching the metallic ends of the two (2) probes together. If the meter reads zero, the meter is in calibration. If it does not read zero, verify the continuity of the probe assembly and re-perform the check. If the meter still does not read zero, consult the factory for repair of the meter.

2. For ground checks, attach one alligator clip to a clean, non-treated surface of the target to be sprayed. Attach the other alligator clip to a known true earth ground. Set the dial to the  $M\Omega$  scale. Read the resistance. If the resistance is greater than  $1.0 M\Omega$  the part is not adequately grounded (reference NFPA-77, NFPA-33).

#### WARNING

- ▶ If the reading between true earth ground and the target is greater than  $1.0 M\Omega$ , then the hooks, racks, supports, etc. must be cleaned and eventually demonstrate a true earth ground resistance of  $1.0 M\Omega$  or lower. See NFPA-33 for further information.

3. For resistance checks, set the meter to  $M\Omega$  scale (see Figure 4). Attach one alligator clip to the electrode wire of a 70430-XX screwed onto a needle shaft (or similar component). Attach the other lead to the shaft of the needle shaft (or other end of a similar component). The electrode reading should be approximately  $14.5 M\Omega$  to  $19M\Omega$ .

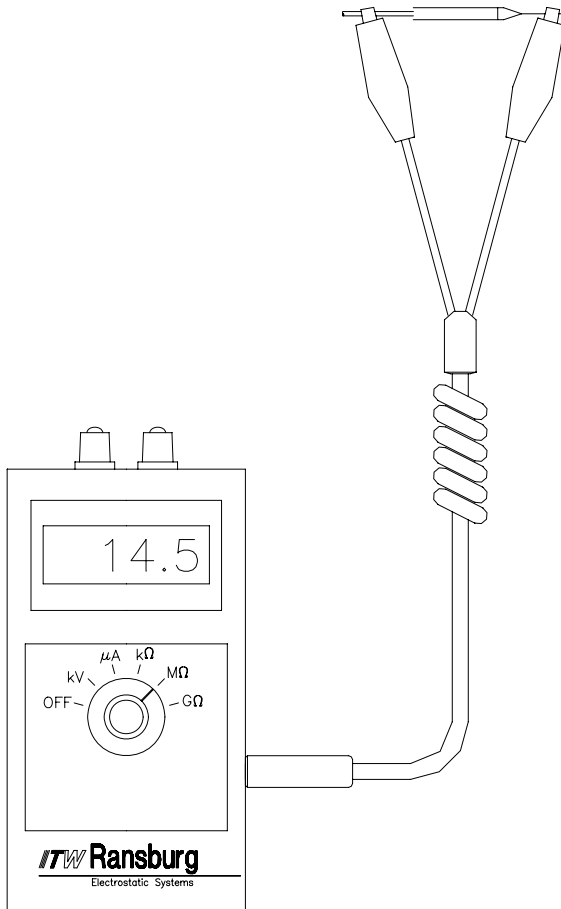

**Figure 4: Measuring Electrode Resistance**

### Short Circuit Current-SCI (Power Supplies)

The ITW Ransburg Multi-Function Meter may be used to measure the short circuit current of an electrostatic product. The short circuit current measurement is important in troubleshooting problems with electrostatic power supplies and applicators. These tests should be performed when a noticeable decrease in transfer efficiency occurs. The measured short circuit current value should be compared to the value listed in the appropriate power supply or applicator manual. This comparison indicates if there are problems with the power source or the applicator.

**CAUTION**

- ▶ Ensure that meter's scale is properly set for the function in which it is being used. Damage to equipment may result if improperly set.

### Operation

**WARNING**

- ▶ Prior to starting the SCI tests, ensure the voltage at the power supply is turned off.

1. Set the meter dial to the  $\mu A$  scale (see Figure 5). Plug the probe with two (2) alligator clamp leads into the side of the meter. Ensure the meter reads zero. If it does not read zero, consult the factory for repair of the meter.

2. Place appropriate test resistor (see Table 2) in the high voltage cable socket of the power supply. Be sure it is pushed clear to the bottom or proper contact will not be made. Attach one of the alligator clamps to the lead of the test resistor. Attach the other alligator clamp to a known true earth ground. Turn the power supply on. Then trigger H.V. by the air flow switch or jumper as required by gun model. (See appropriate service manual for further information.) Be sure that the power supply lights indicate that high voltage is being generated. Measure and record the short circuit current from the meter. This value should be compared to the value listed in the appropriate power supply service manual. A brief listing of ITW Ransburg power supply short circuit current readings is listed in Table 3.

## Short Circuit Current-SCI (Guns)

The ITW Ransburg Multi-Function Meter may be used to measure the short circuit current of an electrostatic applicator. The short circuit current measurement is important in troubleshooting problems with electrostatic power supplies and applicators. These tests should be performed when a noticeable decrease in transfer efficiency occurs. The measured short circuit current value should be compared to the value listed in the appropriate power supply or applicator manual. This comparison indicates if there are problems with the power source or the applicator.

**CAUTION**

▶ Ensure that meter's scale is properly set for the function in which it is being used. Damage to equipment may result if improperly set.

### Operation

**WARNING**

▶ Prior to starting the SCI tests, ensure the voltage at the power supply is turned off.

1. Set the meter dial to the  $\mu\text{A}$  scale (see Figure 5). Plug the probe with two (2) alligator clamp leads into the side of the meter. Check the meter calibration by touching the metallic ends of the two (2) probes together. If the meter reads zero, the meter is in calibration. If it does not read zero, verify the continuity of the probe assembly and re-perform the check. If the meter still does not read zero, consult the factory for repair of the meter.

2. Attach one of the alligator clamps to the electrode (brush on the #2 process bell). Be sure the clamp makes good contact with the electrode (small wires on the #2 brush). Attach the second alligator clamp to ground, preferably the handle or bracket.

3. Apply voltage to the gun from the power supply. The meter should read between the ranges indicated in Table 3. Consult power supply and applicator manuals for readings outside these ranges.

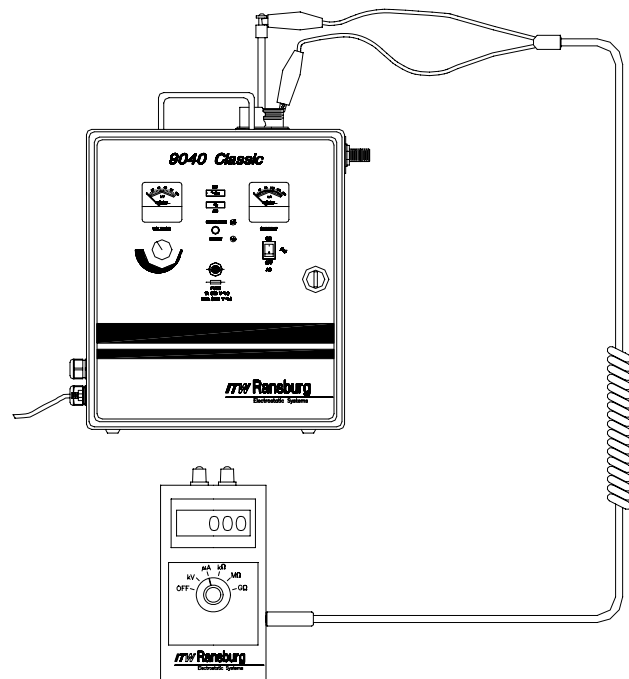

Figure 5: Testing SCI on Power Supplies

Resistor Part No.	Resistance In $\text{M}\Omega$	Power Supply for Use With
16688-01	160	Dry Paks, Porta Paks, 9040 Classic Power Supplies REA-III, REA-IV, REM Classic
16688-02	525	All #2 Power Supplies

Table 2. SCI Test Resistors and Power Supplies

Power Supply in $\mu\text{A}$	SCI Range
79344-XXX, 9050 Classic, Vector R90/70	140 $\mu\text{A}$
76447-10X, 9040 Classic, REA-IV	100-150 $\mu\text{A}$
76447-11X, 9040 Classic, REM Classic	75-100 $\mu\text{A}$
76447-12X, 9040 Classic, REAIII Hand	100-150 $\mu\text{A}$
76447-13X, 9040 Classic, REAIII Auto	125-175 $\mu\text{A}$
76657-14X, 9040 Classic, No. 2 Gun	75-110 $\mu\text{A}$
76304-02,-04, Dry-Pak, REAIV, REH	200-225 $\mu\text{A}$
70918-01, Porta-Pak, REAIII Hand	160-200 $\mu\text{A}$
70394-02, Porta-Pak, REAIII Auto	170-220 $\mu\text{A}$
19219-02, 70360-01, Porta-Pak, No. 2	80-100 $\mu\text{A}$

**Table 3. Power Supplies and SCI Values**

## PAINT RESISTANCE MEASUREMENT KIT

### Paint Resistivity

The ITW Ransburg *Paint Resistance Measurement Kit* using the multi-function meter is designed to provide measurement of the electrical resistance of paint formulations for all electrostatic applications. Once the resistance of a paint is determined and found to spray successfully, measuring resistivity with this meter provides a way to duplicate conditions. This is extremely important when troubleshooting problems with spray or rotational applicators. This meter has two (2) scales,  $\text{M}\Omega$  and  $\text{k}\Omega$  that may be used for measurement of the paint resistance.

### CAUTION

#### ► Testing Metallic Paint

In certain paint formulations where materials of appreciable content of metal flake or powder (i.e., aluminum, bronze, or metallic colors) are used, this method of testing resistance can be misleading or inconclusive. This paint tester will **NOT** indicate the metallic content of the formula.

When using the paint tester with metallic paints, the low voltage battery of the test probe may not be enough to influence the metal particles, therefore, their presence may go unrecognized by the meter. When such formulations are placed in electrostatic applicators and high voltage applied, the metal particles may become aligned by the electrical field. This may result in an appreciable increase of current flow to ground by way of the pain delivery system. While the flow of current poses no immediate dangerous condition, it may drain some or all of the voltage from the electrode and may reduce or eliminate electrostatic efficiency.

### CAUTION

► Ensure that meter's scale is properly set for the function in which it is being used. Damage to equipment may result if improperly set.

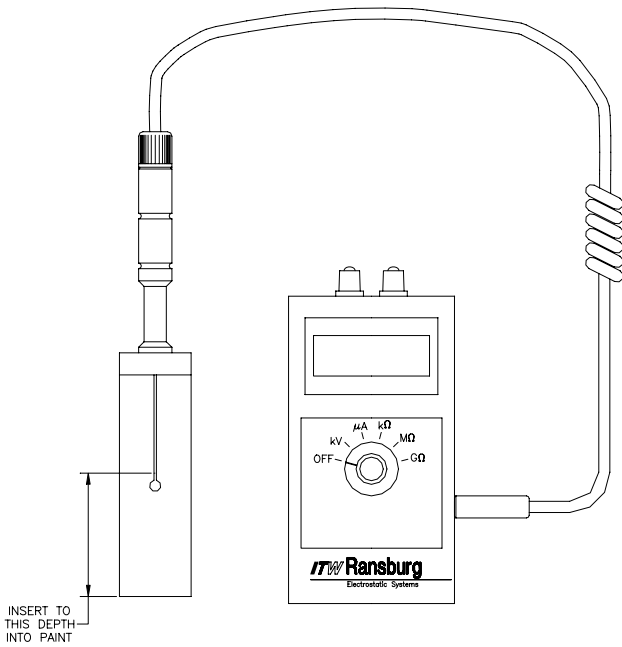

Figure 6: Paint Tester Operation

**Operation**

1. Set the meter dial to the MΩ scale (see Figure 6). Plug the paint probe into the side of the meter.
2. Immerse the probe vertically into a well-mixed representative sample of the subject paint until the holes at the bottom of the slots in the probe sleeve are submerged (see Figure 6). Take a reading within 5 to 10 seconds of submerging the probe.

**⚠ CAUTION**

▶ Do not immerse the paint probe past the top of the sleeve.

**Meter Readings**

Table 4 lists the ranges of paint resistivity that work best for specific ITW Ransburg applicators.

Applicator	Paint Resistivity Range
Aerobell, Aerobell 33, Disks	0.05 MΩ to 1.0MΩ
#2 Process Handgun	0.1 MΩ to 1.0MΩ
Vector, REA, or REM guns	0.1 MΩ to Infinity

**Table 4. Paint Resistivity Ranges \***

*\*Use this table as a guideline. Usually a trial for resistance above listed values is recommended. When resistance is below listed values, electrostatic effect will be reduced due to a higher current draw to ground. To spray this material may require other means of increasing distance to ground such as adding coiled fluid tubes.*

To obtain MΩ - CM from the resistance in MΩ from the meter, multiply by 132.

$$M\Omega - CM = M\Omega \text{ reading} \times 132$$

(Ref. ASTM D5628)

**Maintenance**

The test probe **MUST** be cleaned **IMMEDIATELY** after each use. Use a suitable solvent and clean cloth to thoroughly clean the probe assembly.

1. Remove the probe sleeve and clean it inside and out, removing all paint residues (it may be soaked while probe is cleaned).
2. Thoroughly clean the outside of the probe with the cloth and solvent.

**⚠ CAUTION**

▶ **NEVER** soak the paint probe. There is no solvent seal at the point where the handle screws into the body of the probe. If solvent is allowed to enter at this point or where the cable enters at the top of the handle, the interior wiring will deteriorate and have to be replaced.

3. Place the cleaned sleeve back on the probe.

# HIGH VOLTAGE MEASUREMENT KIT

## High Voltage Measurement

The ITW Ransburg *High Voltage Measurement Kit* using the multi-function meter is designed to provide measurement of high voltage DC potential for all electrostatic applicators to 200kV. Having an accurate measurement of output voltage from an applicator is very important when troubleshooting problems with an installation. The reading from this device indicates whether the applicator and power supply are operating correctly. This kit comes with the following accessories:

1. A high voltage probe assembly to measure DC voltage at a bell, disk or gun.
2. Five (5) feet of 3/8 inch diameter high voltage cable to measure DC voltage from power supplies of 90kV and higher.
3. Five (5) feet of 5/16 inch diameter high voltage cable to measure DC voltage from power supplies producing less than 90kV.

 <b>CAUTION</b>
<p>▶ Ensure that meter's scale is properly set for the function in which it is being used. Damage to equipment may result if improperly set.</p>

### Operation

 <b>CAUTION</b>
<p>▶ DO NOT exceed 30 seconds or less of continuous use of the high voltage probe. The probe is designed for instant readings</p>

 <b>WARNING</b>
<p>▶ The ground clip <b>MUST</b> be connected to a proven true earth ground <b>BEFORE</b> any contact is made between the probe assembly and the assembly being tested. All personnel in the hazard (booth) area <b>MUST</b> be grounded. See ITW Ransburg bulletin "Personnel Grounding".</p>

These operating instructions **MUST** be read and thoroughly understood by all personnel who use this equipment. Special care should be taken to ensure that all Warnings and Requirements for operating the equipment safely are followed.

The user should be aware of and adhere to all relevant local and company safety and fire codes and ordinances and the Occupational Health Act of 1970 (OSHA) prior to operating this equipment.

1. Set the meter dial to the kV scale (see Figure 7). Plug the high voltage probe into the side of the meter.

 <b>WARNING</b>
<p>▶ To provide proper equipment to operator ground, the conductive handle of the probe <b>MUST</b> be held in the bare hand of the operator. To avoid a shock hazard, the meter should <b>NEVER</b> be disconnected from the probe during high voltage contact.</p>

2. Attach ground clamp to a proven earth ground.

**- For Guns**

3. If measuring the voltage on an electrostatic gun, line up the hole in the test probe and the electrode. Slide the test probe straight over the electrode wire of the gun. Be sure to push the test probe tight against the nozzle to minimize any voltage that may leak into the air during the test.

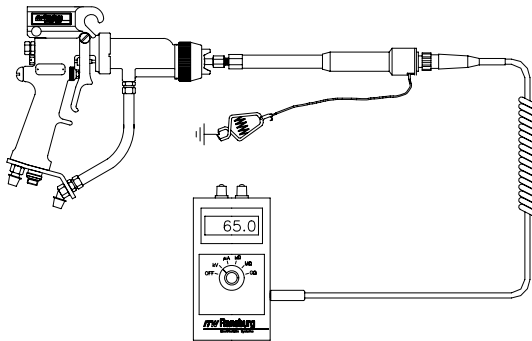

**Figure 7: Measuring High Voltage On Electrostatic Air Spray Gun**

**NOTE**

► Make sure all grounded objects are at least 2 feet away.

4. Holding the metal part of the high voltage probe in your hand, trigger the gun so voltage exists at the electrode.
5. Read the voltage displayed on the meter in 30 seconds or less.
6. Turn the voltage to the gun OFF, and pull the test probe straight off the electrode.

**- For Bells or Disks**

7. Turn the high voltage power supply on.
8. Make and maintain sure contact between the test probe and the applicator (see Figure 8).

**CAUTION**

► Ensure that the applicator is **NOT** rotating when contacting it with the probe. Also, to get proper readings on resistive applicators, the probe must be placed in contact with the atomizing edge of the bell or disk as shown in Figure 8. As this edge is sensitive to mechanical damage, use care when contacting it with the probe. Rough handling may cause damage to the applicator.

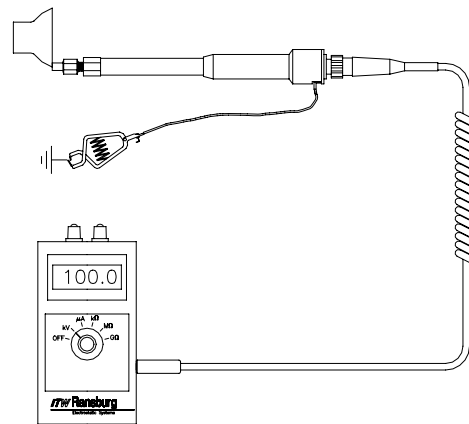

**Figure 8: Measuring High Voltage On Bells or Disks**

9. Read the applicator high voltage displayed on the meter in 30 seconds or less.
10. Disengage the test probe from the applicator.
11. Resume operation.

**- For Power Supply High Voltage Measurement**

12. Remove the metal test rod by loosening the nut on the end of the wand.
13. Insert the proper diameter high voltage cable into the wand of the high voltage probe.
14. Tighten the nut as necessary.
15. Attach the ground clamp to a known true earth ground.

**! WARNING**

► The ground clip **MUST** be connected to a proven true earth ground **BEFORE** any contact is made between the probe assembly and the assembly being tested.

16. Insert the cable into the high voltage tube of the power supply, inserting it far enough to make contact with the contact spring at the bottom of the tube.
  17. Turn the power supply on.
  18. Read the voltage displayed on the meter, 30 seconds or less.
  19. Turn the power supply off.
  20. Disengage the probe cable from the power supply.
  21. Restore the applicator connection to the power supply and resume operation.
- For Probe (Electrode) Assemblies**
22. Turn on the high voltage power supply.
  23. Place adapter on end of high voltage probe (see Figure 9).

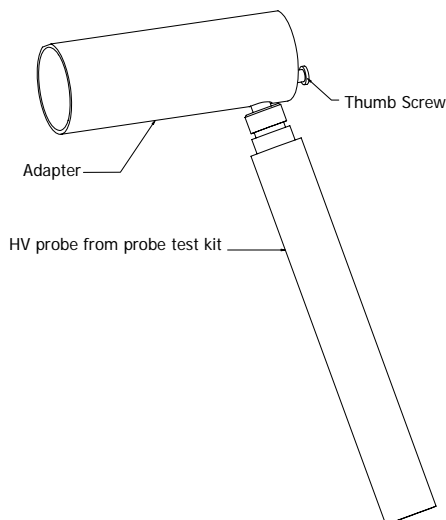

**Figure 9: Probe Assembly View**

24. Tighten thumb screw.
25. Place adapter over probe (electrode) assembly (see Figure 10).

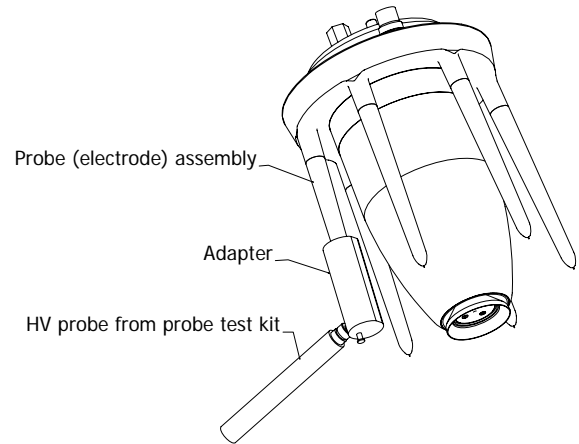

**Figure 10: Electrode Test View**

26. Remove adapter from probe (electrode) assembly.
27. Test other probe (electrode) assemblies or resume operation.

**Maintenance - Probe**

1. Keep the test probe and the HV cables clean to prevent contamination of the probe sockets. Clean only with non-polar solvents.
2. Inspect the ground cable, its clamp and connections for breaks or poor connections.
3. Do not bend or stress the white kV probe assembly, as this may break the potted high voltage resistor.

## GENERAL MAINTENANCE

### Maintenance - Battery Replacement

When required, the battery will need to be replaced. It may be purchased locally and is a standard alkaline type 9V battery. To replace the battery, perform the following steps (refer to Figure 11).

1. Remove the sliding back cover of the meter.
2. Remove the existing battery from the two (2) prong 9V connector.
3. Replace with new alkaline 9V battery.
4. Replace back cover.
5. Appropriately discard used battery.

#### NOTE

- ▶ The screen will go blank when the battery needs to be replaced.

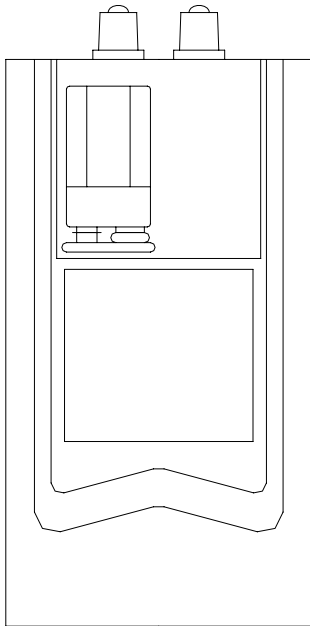

Figure 11: Battery Replacement

### Calibration

The 76634-00 Multi-Function Meter is not field repairable. The meter should be returned to the factory for repair or recalibration.

ITW Ransburg recommends that the Multi-Function Meter and its associated equipment (Paint probe, kV Probe, and/or Test Leads) be sent in together for recalibration at least once per year.

#### NOTE

- ▶ The best recalibration results the Multi-Function Meter and accessories (Paint probe, kV Probe, and/or Test Leads) should be sent in together for recalibration.

When shipped from the factory, and after each calibration, the Multi-Function Meter will be sealed with a calibration sticker noting the next date when calibration expires. Removal of this seal will void calibration of the unit. A certificate of calibration will also be shipped with each calibrated unit.

NOTES

---

# WARRANTY POLICIES

---

## LIMITED WARRANTY

ITW Ransburg will replace or repair without charge any part and/or equipment that falls within the specified time (see below) because of faulty workmanship or material, provided that the equipment has been used and maintained in accordance with ITW Ransburg's written safety and operating instructions, and has been used under normal operating conditions. Normal wear items are excluded.

**THE USE OF OTHER THAN ITW RANSBURG APPROVED PARTS, VOID ALL WARRANTIES.**

**SPARE PARTS:** One hundred and eighty (180) days from date of purchase, except for rebuilt parts (any part number ending in "R") for which the warranty period is ninety (90) days.

**EQUIPMENT:** When purchased as a complete unit, (i.e., guns, power supplies, control units, etc.), is one (1) year from date of purchase. **WRAPPING THE APPLICATOR, ASSOCIATED VALVES AND TUBING, AND SUPPORTING HARDWARE IN PLASTIC, SHRINK-WRAP, OR ANY OTHER NON-APPROVED COVERING, WILL VOID THIS WARRANTY.**

**ITW RANSBURG'S ONLY OBLIGATION UNDER THIS WARRANTY IS TO REPLACE PARTS THAT HAVE FAILED BECAUSE OF FAULTY WORKMANSHIP OR MATERIALS. THERE ARE NO IMPLIED WARRANTIES NOR WARRANTIES OF EITHER MERCHANTABILITY OR FITNESS FOR A PARTICULAR PURPOSE. ITW RANSBURG ASSUMES NO LIABILITY FOR INJURY, DAMAGE TO PROPERTY OR FOR CONSEQUENTIAL DAMAGES FOR LOSS OF GOODWILL OR PRODUCTION OR INCOME, WHICH RESULT FROM USE OR MISUSE OF THE EQUIPMENT BY PURCHASER OR OTHERS.**

### EXCLUSIONS:

If, in ITW Ransburg's opinion the warranty item in question, or other items damaged by this part was improperly installed, operated or maintained, ITW Ransburg will assume no responsibility for repair or replacement of the item or items. The purchaser, therefore will assume all responsibility for any cost of repair or replacement and service related costs if applicable.

# APPENDIX

## PAINT AND SOLVENT SPECIFICATIONS

	REA™ VECTOR™ EFM™ EVOLVER™	REM™ / M90™	NO. 2 HAND GUN	TURBODISK™	AEROBELL® II*** AEROBELL® AEROBELL® 33 RMA-101™
RECOMMENDED VISCOSITY USING A ZAHN NO. 2	18 TO 30 SEC	18 TO 30 SEC	20 TO 60 SEC	20 TO 60 SEC	20 TO 60 SEC
PAINT ELECTRICAL RESISTANCE**	.1 MΩ TO ∞	.1 MΩ TO ∞	.1 TO 1 MΩ	.1 MΩ TO ∞	.1 MΩ TO ∞
RECOMMENDED DELIVERY (UP TO)	1000 cc/min	1500 cc/min	180 cc/min	1000 cc/min	500 cc/min

### GUIDE TO USABLE SOLVENT SELECTION

Chemical Name	Common Name	Category	Flash Point†† (TCC)	*CAS Number	Evap. Rate†	Elec. Res.**
DICHLOROMETHANE	Methylene Chloride	Chlorinated Solvents		75-09-2	14.5	HIGH
VM & P NAPHTHA	Naptha	Aliphatic Hydrocarbons	65°F	8030-30-6	10	HIGH
ACETONE		Ketones	-18°F	67-64-1	5.6	LOW
METHYL ACETATE		Esters	90°F	79-20-9	5.3	LOW
BENZENE		Aromatic Hydrocarbons	12°F	71-43-2	5.1	HIGH
ETHYL ACETATE		Esters	24°F	141-78-6	3.9	MEDIUM
2-BUTANONE	MEK	Ketones	16°F	78-93-3	3.8	MEDIUM
ISO-PROPYL ACETATE		Esters	35°F	108-21-4	3.4	LOW
ISOPROPYL ALCOHOL	IPA	Alcohols	53°F	67-63-0	2.5	LOW
2-PENTANONE	MPK	Ketones	104°F	107-87-9	2.5	MEDIUM
METHANOL	Methyl Alcohol	Alcohols	50°F	67-56-1	2.1	LOW
PROPYL ACETATE	n-Propyl Acetate	Esters	55°F	109-60-4	2.1	LOW
TOLUOL	Toluene	Aromatic Hydrocarbons	48°F	108-88-3	1.9	HIGH
METHYL ISOBUTYL KETONE	MIBK	Ketones	60°F	108-10-1	1.6	MEDIUM
ISOBUTYL ACETATE		Esters	69°F	110-19-0	1.5	LOW
ETHANOL	Ethyl Alcohol	Alcohols		64-17-5	1.4	LOW
<b>BUTYL ACETATE</b>		<b>Esters</b>	<b>78°F</b>	<b>123-86-4</b>	<b>1.0</b>	<b>LOW</b>
ETHYLBENZENE		Aromatic Hydrocarbons	64°F	100-41-4	.89	HIGH
1-PROPANOL	n-Propyl Alcohol	Alcohols	74°F	71-23-8	.86	LOW
2-BUTANOL	sec.-Butyl Alcohol	Alcohols	72°F	78-92-2	.81	LOW
XYLOL	Xylene	Aromatic Hydrocarbons	79°F	1330-02-07	.80	HIGH
AMYL ACETATE		Esters	106°F	628-63-7	.67	MEDIUM
2-METHYLPROPANOL	iso-Butyl Alcohol	Alcohols	82°F	78-83-1	.62	LOW
METHYL AMYL ACETATE		Esters	96°F	108-84-9	.50	LOW
5-METHYL-2-HEXANONE	MIAK	Ketones	96°F	110-12-3	.50	MEDIUM
1-BUTANOL	n-Butyl Alcohol	Alcohols	95°F	71-36-3	.43	LOW
2-ETHOXYETHANOL		Glycol Ethers	164°F	110-80-5	.38	LOW
2-HEPTANONE	MAK	Ketones	102°F	110-43-0	.40	MEDIUM
CYCLOHEXANONE		Ketones	111°F	108-94-1	.29	MEDIUM
AROMATIC-100	SC#100	Aromatic Hydrocarbons	111°F		.20	HIGH
DIISOBUTYL KETONE	DIBK	Ketones	120°F	108-83-8	.19	MEDIUM
1-PENTANOL	Amyl Alcohol	Alcohols		71-41-0	.15	LOW
DIACETONE ALCOHOL		Ketones	133°F	123-42-2	.12	LOW
2-BUTOXYETHANOL	Butyl Cellosolve	Glycol Ethers	154°F	111-76-2	.07	LOW
CYCLOHEXANOL		Alcohols	111°F	108-93-0	.05	LOW
AROMATIC-150	SC#150	Aromatic Hydrocarbons	149°F		.004	HIGH
AROMATIC-200		Aromatic Hydrocarbons	203°F		.003	HIGH

\* CAS Number: Chemical Abstract Service Number.

\*\* Electrical Resistance using the ITW Ransburg Meter.

\*\*\* Solvent Base Configuration Only.

† Information Obtained From: <http://solvdb.ncms.org>

†† The lowest temperature at which a volatile fluid will ignite.

**Evaporation Rate is Based Upon Butyl Acetate Having a Rate of 1.0**

**NOTE:** Chart provides resistance and control information that we feel is necessary when using ITW Ransburg equipment.

© 05/2006 Illinois Tool Works Inc. All rights reserved.

VISCOSITY CONVERSION CHART																		
Poise	Centipoise	DuPont Parlin 7	DuPont Parlin 10	Fisher 1	Fisher 2	Ford Cup 3	Ford Cup 4	Gardner - Holdt Bubble	Gardner - Lithographic	Krebs Unit KU	Saybolt Universal SSU	Zahn 1	Zahn 2	Zahn 3	Zahn 4	Zahn 5	Sears Craftsman Cup	Din Cup 4
.1	10	27	11	20			5	A-4			60	30	16					10
.15	15	30	12	25			8	A-3			80	34	17					11
.2	20	32	13	30	15	12	10				100	37	18					12
.25	25	37	14	35	17	15	12	A-2			130	41	19					13
.3	30	43	15	39	18	19	14	A-1			160	44	20					14
.4	40	50	16	50	21	25	18	A			210	52	22				19	15
.5	50	57	17		24	29	22			30	260	60	24				20	16
.6	60	64	18		29	33	25	B		33	320	68	27				21	18
.7	70		20		33	36	28			35	370		30				23	21
.8	80		22		39	41	31	C		37	430		34				24	23
.9	90		23		44	45	32			38	480		37	10			26	25
1.0	100		25		50	50	34	D		40	530		41	12	10		27	27
1.2	120		30		62	58	41	E		43	580		49	14	11		31	31
1.4	140		32			66	45	F		46	690		58	16	13		34	34
1.6	160		37				50	G		48	790		66	18	14		38	38
1.8	180		41				54		000	50	900		74	20	16		40	43
2.0	200		45				58	H		52	1000		82	23	17	10	44	46
2.2	220						62	I		54	1100			25	18	11		51
2.4	240						65	J		56	1200			27	20	12		55
2.6	260						68			58	1280			30	21	13		58
2.8	280						70	K		59	1380			32	22	14		63
3.0	300						74	L		60	1475			34	24	15		68
3.2	320							M			1530			36	25	16		72
3.4	340							N			1630			39	26	17		76
3.6	360							O		62	1730			41	28	18		82
3.8	380										1850			43	29	19		86
4.0	400							P		64	1950			46	30	20		90
4.2	420										2050			48	32	21		95
4.4	440							Q			2160			50	33	22		100
4.6	460							R		66	2270			52	34	23		104
4.8	480								00	67	2380			54	36	24		109
5.0	500							S		68	2480			57	37	25		112
5.5	550							T		69	2660			63	40	27		124
6.0	600							U		71	2900			68	44	30		135
7.0	700									74	3375				51	35		160
8.0	800								0	77	3380				58	40		172
9.0	900							V		81	4300				64	45		195
10.0	1000							W		85	4600					49		218
11.0	1100									88	5200					55		
12.0	1200									92	5620					59		

<b>VISCOSITY CONVERSION CHART (Continued)</b>																		
Poise	Centipoise	DuPont Parlin 7	DuPont Parlin 10	Fisher 1	Fisher 2	Ford Cup 3	Ford Cup 4	Gardner - Holdt Bubble	Gardner - Lithographic	Krebs Unit KU	Saybolt Universal SSU	Zahn 1	Zahn 2	Zahn 3	Zahn 4	Zahn 5	Sears Craftsman Cup	Din Cup 4
13.0	1300							X		95	6100					64		
14.0	1400								1	96	6480							
15.0	1500									98	7000							
16.0	1600									100	7500							
17.0	1700									101	8000							
18.0	1800							Y			8500							
19.0	1900										9000							
20.0	2000									103	9400							
21.0	2100										9850							
22.0	2200										10300							
23.0	2300							Z	2	105	10750							
24.0	2400									109	11200							
25.0	2500							Z-1		114	11600							
30.0	3000									121	14500							
35.0	3500							Z-2	3	129	16500							
40.0	4000									133	18500							
45.0	4500							Z-3		136	21000							
50.0	5000										23500							
55.0	5500										26000							
60.0	6000							Z-4	4		2800							
65.0	6500										30000							
70.0	7000										32500							
75.0	7500										35000							
80.0	8000										37000							
85.0	8500										39500							
90.0	9000										41000							
95.0	9500										43000							
100.0	10000							Z-5	5		46500							
110.0	11000										51000							
120.0	12000										55005							
130.0	13000										60000							
140.0	14000										65000							
150.0	15000							Z-6			67500							
160.0	16000										74000							
170.0	17000										83500							
180.0	18000										83500							
190.0	19000										88000							
200.0	20000										93000							
300.0	30000										140000							

**Note:** All viscosity comparisons are as accurate as possible with existing information. Comparisons are made with a material having a specific gravity of 1.0.

<b>VOLUMETRIC CONTENT OF HOSE OR TUBE (English Units)</b>							
<b>I.D. (inches)</b>	<b>cc/ft.</b>	<b>Cross Section (sq. in.)</b>	<b>Length</b>				
			<b>5ft. (60")</b>	<b>10ft. (120")</b>	<b>15ft. (180")</b>	<b>25ft. (300")</b>	<b>50ft. (600")</b>
1/8	2.4	.012	.003 gal. .4 fl. oz.	.006 gal. .8 fl. oz.	.010 gal. 1.2 fl. oz.	.016 gal. 2.0 fl. oz.	.032 gal. 4.1 fl. oz.
3/16	5.4	.028	.007 gal. .9 fl. oz.	.014 gal. 1.8 fl. oz.	.022 gal. 2.8 fl. oz.	.036 gal. 4.6 fl. oz.	.072 gal. 9.2 fl. oz.
1/4	9.7	.049	.013 gal. 1.6 fl. oz.	.025 gal. 3.3 fl. oz.	.038 gal. 4.9 fl. oz.	.064 gal. 8.2 fl. oz.	.127 gal. 16.3 fl. oz.
5/16	15.1	.077	.020 gal. 2.5 fl. oz.	.040 gal. 5.1 fl. oz.	.060 gal. 7.6 fl. oz.	.100 gal. 12.7 fl. oz.	.199 gal. 25.5 fl. oz.
3/8	21.7	.110	.029 gal. 3.7 fl. oz.	.057 gal. 7.3 fl. oz.	.086 gal. 11.0 fl. oz.	.143 gal. 18.4 fl. oz.	.287 gal. 36.7 fl. oz.
1/2	38.6	.196	.051 gal. 6.5 fl. oz.	.102 gal. 13.1 fl. oz.	.153 gal. 19.6 fl. oz.	.255 gal. 32.6 fl. oz.	.510 gal. 65.3 fl. oz.

<b>VOLUMETRIC CONTENT OF HOSE OR TUBE (Metric Units)</b>							
<b>I.D. (mm)</b>	<b>cc/m</b>	<b>Cross Section (mm<sup>2</sup>)</b>	<b>Length</b>				
			<b>1.5m</b>	<b>3.0m</b>	<b>4.5m</b>	<b>6.0m</b>	<b>7.5m</b>
3.6	10.2	10.2	15.3 cc	30.5 cc	45.8 cc	61.1 cc	76.3 cc
5.6	24.6	24.6	36.9 cc	73.9 cc	110.8 cc	147.8 cc	184.7 cc
6.8	36.3	36.3	54.5 cc	109.0 cc	163.4 cc	217.9 cc	272.4 cc
8.8	60.8	60.8	91.2 cc	182.5 cc	273.7 cc	364.9 cc	456.2 cc

© 05/2004 Illinois Tool Works Inc. All rights reserved.

# MANUAL CHANGE SUMMARY

This manual was published to replace Service Manual **TE-98-01.4, Paint, High Voltage & SCI Test Equipment**, to make the following changes:

1. Added "A11757-00 High Voltage Probe Adapter" on the "Front Cover."
2. Added "A11757-00 High Voltage Probe Adapter" in the "Multi-Function Electrostatic Meter" section.
3. Added new "Figure 9 - Probe Assembly View".
4. Added new "Figure 10 - Electrode Test View".

**Manufacturing**

1910 North Wayne Street  
Angola, Indiana 46703-9100  
Telephone: 260/665-8800  
Fax: 260/665-8516

**Technical/Service Assistance**

Automotive Assembly and Tier I  
Industrial Systems  
Ransburg Guns

Telephone: 800/ 626-3565 Fax: 419/ 470-2040  
Telephone: 800/ 233-3366 Fax: 419/ 470-2071  
Telephone: 800/ 233-3366 Fax: 419/ 470-2071

**Technical Support Representative will direct you to the appropriate telephone number for ordering Spare Parts.**