

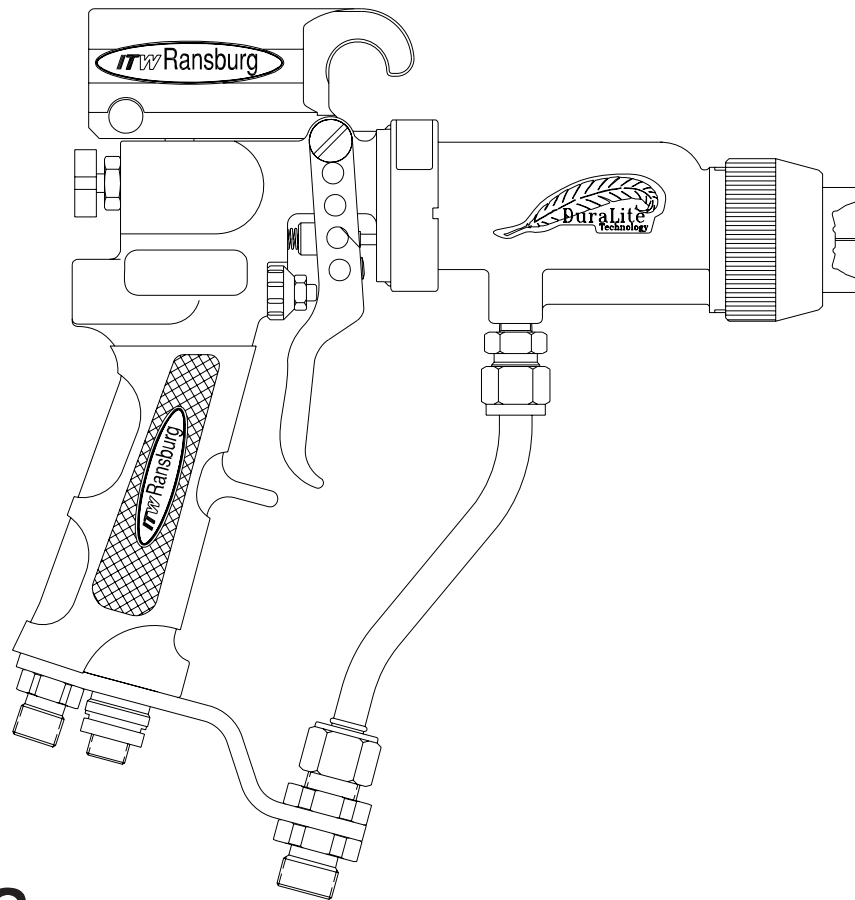

REA-70 and REA-70L ELECTROSTATIC APPLICATORS Dual Atomization Technology



MODELS:

72074 FOR STANDARD 9040

75980 FOR AVIATOR/MGS



IMPORTANT: Before using this equipment, carefully read **SAFETY PRECAUTIONS**, starting on page 1, and all instructions in this manual. Keep this Service Manual for future reference.

Service Manual Price: €25.00 (Euro)
\$30.00 (U.S.)

NOTE: This manual has been changed from revision **AH-93-01.6** to revision **AH-93-01.7** .
Reasons for this change are noted under “Manual Change Summary” inside the back cover of this manual.

CONTENTS

	PAGE
SAFETY:	1-6
SAFETY PRECAUTIONS.....	1
HAZARDS / SAFEGUARDS.....	2-6
ATEX	7-10
EUROPEAN ATEX DIRECTIVE.....	7
EUROPEAN ATEX LABELS.....	8-9
INTRODUCTION:	11-14
GENERAL DESCRIPTION.....	11
REA-70 WITH AVIATOR.....	11
SPECIFICATIONS.....	12
REA-70 AND 70L STANDARD SPRAY APPLICATOR FEATURES.....	13
REA-70 AND 70L AVIATOR/MGS SPRAY APPLICATOR FEATURES.....	14
INSTALLATION:	15-22
72074 STANDARD SOLVENT BASE AND 75980 AVIATOR / MGS	
SOLVENT BASE INSTALLATION.....	15-16
FILTERS.....	16
FLUID HOSE FITTING INSTALLATION.....	17
AIR HOSE FITTING INSTALLATION.....	17
PAINT PREPARATION.....	17
SPRAY TECHNOLOGY CONVERSION PROCEDURE.....	18
SPRAY PATTERN ADJUSTMENT.....	19
APPLICATOR TO TARGET DISTANCE.....	19-20
AIR CAP / FLUID NOZZLE SELECTION CHART.....	21
AIR CAP / FLUID NOZZLE PERFORMANCE CHART.....	22
MAINTENANCE:	23-54
SUITABLE SOLVENTS FOR CLEANING REA-70 APPLICATORS.....	23
ROUTINE SCHEDULE.....	24-25
APPLICATOR ASSEMBLY CLEANING PROCEDURE.....	25-26
FLUSHING PROCEDURES.....	27
APPLICATOR REPAIR.....	27
EQUIPMENT REQUIRED.....	27
TO REMOVE THE APPLICATOR FROM THE WORK SITE.....	28
AIR CAP.....	29
FLUID NOZZLE.....	29-30
NEEDLE / ELECTRODE.....	30

(Continued On Next Page)

CONTENTS (Cont.)

	PAGE
MAINTENANCE (Cont.):	23-54
NEEDLE / ELECTRODE RESISTANCE TESTING.....	31
BARREL ASSEMBLY.....	31-36
HOOK / TRANSFORMER ASSEMBLY.....	37-38
HOOK / TRANSFORMER ON/OFF SWITCH REPLACEMENT.....	39
HANDLE.....	39-40
FAN AIR VALVE.....	40-41
AIR VALVE.....	41-42
TRIGGER.....	42-43
NEEDLE SHAFT RETURN SPRING REPLACEMENT.....	43
LOW VOLTAGE CABLE PLUG ASSEMBLY REPLACEMENT.....	44-45
LOW VOLTAGE CABLE REPLACEMENT.....	45
FLUID TUBE.....	46-47
FLUID HOSE.....	47
AIR LINE.....	47
FLUID TUBE BRACKET.....	48
TRIGGER ADJUSTMENT.....	48-49
FAN AIR ADJUSTMENT.....	49
FLUID DELIVERY ADJUSTMENT.....	49
ATOMIZING AIR ADJUSTMENT.....	49
TROUBLESHOOTING GUIDE.....	51-53
PARTS IDENTIFICATION:	55-62
72074 (STANDARD) AND 75980 (AVIATOR / MGS).....	55
72074 SOLVENT BASE REA-70 STANDARD MODEL IDENTIFICATION.....	56
75980 SOLVENT BASE REA-70 AVIATOR / MGS MODEL IDENTIFICATION.....	56
REA-70 AND 70L SPRAY APPLICATORS PARTS LIST.....	57-59
RECOMMENDED SPARE PARTS.....	61
MISC. PARTS.....	61
SERVICE KITS.....	62
WARRANTY POLICIES:	63
LIMITED WARRANTY.....	63

SAFETY

SAFETY PRECAUTIONS

Before operating, maintaining or servicing any ITW Ransburg electrostatic coating system, read and understand all of the technical and safety literature for your ITW Ransburg products. This manual contains information that is important for you to know and understand. This information relates to **USER SAFETY** and **PREVENTING EQUIPMENT PROBLEMS**. To help you recognize this information, we use the following symbols. Please pay particular attention to these sections.

A WARNING! states information to alert you to a situation that might cause serious injury if instructions are not followed.

A CAUTION! states information that tells how to prevent damage to equipment or how to avoid a situation that might cause minor injury.

A NOTE is information relevant to the procedure in progress.

While this manual lists standard specifications and service procedures, some minor deviations may be found between this literature and your equipment. Differences in local codes and plant requirements, material delivery requirements, etc., make such variations inevitable. Compare this manual with your system installation drawings and appropriate ITW Ransburg equipment manuals to reconcile such differences.

Careful study and continued use of this manual will provide a better understanding of the equipment and process, resulting in more efficient operation, longer trouble-free service and faster, easier troubleshooting. If you do not have the manuals and safety literature for your Ransburg system, contact your local ITW Ransburg representative or ITW Ransburg.



WARNING

- ▶ The user **MUST** read and be familiar with the Safety Section in this manual and the ITW Ransburg safety literature therein identified.
- ▶ This manual **MUST** be read and thoroughly understood by **ALL** personnel who operate, clean or maintain this equipment! Special care should be taken to ensure that the **WARNINGS** and safety requirements for operating and servicing the equipment are followed. The user should be aware of and adhere to **ALL** local building and fire codes and ordinances as well as **NFPA-33 SAFETY STANDARD**, prior to installing, operating, and/or servicing this equipment.

WARNING

- ▶ The hazards shown on the following page may occur during the normal use of this equipment. Please read the hazard chart beginning on page 2.

<p>AREA Tells where hazards may occur.</p>	<p>HAZARD Tells what the hazard is.</p>	<p>SAFEGUARDS Tells how to avoid the hazard.</p>
<p>Spray Area</p> 	<p>Fire Hazard</p> <p>Improper or inadequate operation and maintenance procedures will cause a fire hazard.</p> <p>Protection against inadvertent arcing that is capable of causing fire or explosion is lost if any safety interlocks are disabled during operation. Frequent power supply shutdown indicates a problem in the system requiring correction.</p>	<p>Fire extinguishing equipment must be present in the spray area and tested periodically.</p> <p>Spray areas must be kept clean to prevent the accumulation of combustible residues.</p> <p>Smoking must never be allowed in the spray area.</p> <p>The high voltage supplied to the atomizer must be turned off prior to cleaning, flushing or maintenance.</p> <p>When using solvents for cleaning:</p> <p>Those used for equipment flushing should have flash points equal to or higher than those of the coating material.</p> <p>Those used for general cleaning must have flash points above 100°F (37.8°C).</p> <p>Spray booth ventilation must be kept at the rates required by NFPA-33, OSHA, and local codes. In addition, ventilation must be maintained during cleaning operations using flammable or combustible solvents.</p> <p>Electrostatic arcing must be prevented.</p> <p>Test only in areas free of combustible material.</p> <p>Testing may require high voltage to be on, but only as instructed.</p> <p>Non-factory replacement parts or unauthorized equipment modifications may cause fire or injury.</p> <p>If used, the key switch bypass is intended for use only during setup operations. Production should never be done with safety interlocks disabled.</p> <p>The paint process and equipment should be set up and operated in accordance with NFPA-33, NEC, and OSHA requirements.</p>

AREA Tells where hazards may occur.	HAZARD Tells what the hazard is.	SAFEGUARDS Tells how to avoid the hazard.
Toxic Substances 	Certain material may be harmful if inhaled, or if there is contact with the skin.	Follow the requirements of the Material Safety Data Sheet supplied by coating material manufacturer. Adequate exhaust must be provided to keep the air free of accumulations of toxic materials. Use a mask or respirator whenever there is a chance of inhaling sprayed materials. The mask must be compatible with the material being sprayed and its concentration. Equipment must be as prescribed by an industrial hygienist or safety expert, and be NIOSH approved.
Explosion Hazard / Incompatible Materials 	Halogenated hydrocarbon solvents, for example: methylene chloride and 1,1,1, - Trichloroethane, are not chemically compatible with the aluminum that might be used in many system components. The chemical reaction caused by these solvents reacting with aluminum can become violent and lead to an equipment explosion.	The REA-70 and REA-70L require that aluminum inlet fittings be replaced with stainless steel. (See accessories list.) Aluminum is widely used in other spray application equipment - such as material pumps, regulators, valves, etc. Check all other equipment items before use and make sure they can also be used safely with these solvents. Read the label or data sheet for the material you intend to spray. If in doubt as to whether or not a coating or cleaning material is compatible, contact your material supplier. Any other type of solvent may be used with aluminum equipment.
Electrical Equipment 	<p>High voltage equipment is utilized. Arcing in areas of flammable or combustible materials may occur. Personnel are exposed to high voltage during operation and maintenance.</p> <p>Protection against inadvertent arcing that may cause a fire or explosion is lost if safety circuits are disabled during operation.</p> <p>Frequent power supply shutdown indicates a problem in the system which requires correction.</p> <p>An electrical arc can ignite coating materials and cause a fire or explosion.</p>	<p>The power supply, optional remote control cabinet, and all other electrical equipment must be located outside Class I or II, Division 1 and 2 hazardous areas. (Exception: AVIATOR series applicators) Refer to NFPA-33.</p> <p>Turn the power supply OFF before working on the equipment.</p> <p>Test only in areas free of flammable or combustible material.</p> <p>Testing may require high voltage to be on, but only as instructed.</p> <p>Production should never be done with the safety circuits disabled.</p> <p>Before turning the high voltage on, make sure no objects are within the sparking distance.</p>

<p>AREA Tells where hazards may occur.</p>	<p>HAZARD Tells what the hazard is.</p>	<p>SAFEGUARDS Tells how to avoid the hazard.</p>
<p>Spray Area</p> 	<p>Electrostatic Arcing</p>	<p>Never operate the spray applicator without properly grounding the following.</p> <p>A. Operators</p> <p>Operators must be grounded. Rubber soled insulating shoes should not be worn. Grounding leg straps may be used.</p> <p>Operators must maintain contact with the handle of the applicator. If work gloves are used, the palm section should be cut out.</p> <p>Operators must remove from themselves all metal objects that are not grounded.</p> <p>NOTE: REFER TO NFPA-33 REGARDING OPERATOR GROUNDING.</p> <p>B. Parts being sprayed. Resistance between the part and a grounded conveyor must not exceed 1 megohm.</p> <p>C. Every metal and conductive object in the spray area. This includes the booth, parts hangers, fire extinguishers, conductive flooring, etc.</p> <p>Grounded conductive flooring must be provided in the spray area.</p> <p>Turn off voltage at the power supply before flushing out, cleaning, or removing any parts from the applicator.</p> <p>Never install a spray applicator into a fluid system using an isolated solvent supply.</p> <p>Do not touch applicator electrode while applicator is energized.</p>

AREA Tells where hazards may occur.	HAZARD Tells what the hazard is.	SAFEGUARDS Tells how to avoid the hazard.
<p>General Use and Maintenance</p> 	<p>Improper operation or maintenance may create a hazard.</p> <p>Personnel must be properly trained in the use of this equipment.</p>	<p>Personnel must be given training in accordance with the requirements of NFPA-33.</p> <p>Instructions and safety precautions must be read and understood prior to using this equipment.</p> <p>Comply with appropriate local, state, and national codes governing ventilation, fire protection, operation maintenance, and housekeeping. Reference OSHA, NFPA-33, and your insurance company requirements.</p> <p>Always turn power to the power supply OFF, unplug the electrical cord from its outlet, and remove the front panel fuse, before opening the power supply door. If necessary, lock the power supply out so that it cannot be turned ON until the work is finished.</p> <p>Whenever removing high voltage cables from equipment, ground the contact end of the cable by holding the cable such that the contact touches earth ground for several seconds. Do not touch the contact until it has been grounded. This will reduce the possibility of residual charge causing electrical shock.</p> <p>The High Voltage Multiplier Assembly contains energy storage components that can cause serious shock injury, and therefore is not field repairable. Warranty will be voided if the High Voltage Multiplier seal is broken. If the High Voltage Multiplier is defective contact your authorized ITW Ransburg representative for exchange or repair.</p> <p>The High Voltage Multiplier and high voltage cable contain significant capacitance that will store charge. Allow approximately 10 seconds for this charge to bleed off before opening the cabinet door or removing the high voltage cable from the power supply or spray applicator.</p>

AREA Tells where hazards may occur.	HAZARD Tells what the hazard is.	SAFEGUARDS Tells how to avoid the hazard.
<p>General Use and Maintenance</p> 	<p>Use of hand tools may cause cumulative trauma disorders (CTD's). CTD's or musculoskeletal disorders, involve damage to the hands, wrists, elbows, shoulders, neck and back. Carpal tunnel syndrome and tendinitis (such as tennis elbow or rotator cuff syndrome) are examples of CTD's.</p> <p>CTD's when using hand tools, tend to affect the upper extremities. Factors which may increase the risk of developing a CTD include:</p> <ol style="list-style-type: none"> 1. High frequency of the activity. 2. Excessive force, such as gripping, pinching or pressing with the hands and fingers. 3. Extreme or awkward finger, wrist or arm positions. 4. Excessive duration of the activity. 5. Tool vibration. 6. Repeated pressure on a body part. 7. Working in cold temperatures. 	<p>Risk is reduced by avoiding or lessening the listed hazards.</p> <p>CTD's can also be caused by such activities as sewing, golf, tennis and bowling, to name a few.</p> <p>Pain, tingling, or numbness in the shoulder, forearm, wrists, hands, or fingers, especially during the night, may be early symptoms of a CTD. Do not ignore them. Should you experience any such symptoms, see a physician immediately. Other early symptoms may include vague discomfort in the hand, loss of manual dexterity, and nonspecific pain in the arm. Ignoring early symptoms and continued repetitive use of the arm, wrist and hand can lead to serious disability.</p>

EUROPEAN ATEX DIRECTIVE 94/9/EC, ANNEX II, 1.0.6

The following instructions apply to equipment covered by certificate number Sira 08ATEX5040X:

1. The equipment may be used with flammable gases and vapors with apparatus groups II and with temperature class T6.
2. The equipment is only certified for use in ambient temperatures in the range +12.8°C to +40°C and should not be used outside this range.
3. Installation shall be carried out by suitably trained personnel in accordance with the applicable code of practice e.g. EN 60079-14:1997.
4. Inspection and maintenance of this equipment shall be carried out by suitably trained personnel in accordance with the applicable code of practice e.g. EN 60079-17.
5. Repair of this equipment shall be carried out by suitable trained personnel in accordance with the applicable code of practice e.g. EN 60079-19.
6. Putting into service, use, assembling, and adjustment of the equipment shall be fitted by suitably trained personnel in accordance with the manufacturer's documentation.

Refer to the "Table of Contents" of this service manual:

- a. Installation
- b. Operation
- c. Maintenance
- d. Parts Identification

7. Components to be incorporated into or used as replacement parts of the equipment shall be fitted by suitably trained personnel in accordance with the manufacturer's documentation.

8. The certification of this equipment relies upon the following materials used in its construction:

If the equipment is likely to come into contact with aggressive substances, then it is the responsibility of the user to take suitable precautions that prevent it from being adversely affected, thus ensuring that the type of protection provided by the equipment is not compromised.

Aggressive substances: e.g. acidic liquids or gases that may attack metals, or solvents that may affect polymeric materials.

Suitable precautions: e.g. regular checks as part of routine inspections or establishing from the material's data sheets that it is resistant to specific chemicals.

Refer to "Specifications" in the "Introduction" section:

- a. All fluid passages contain stainless steel or nylon fittings.
- b. High voltage cascade is encapsulated with a solvent resistant epoxy.

9. A recapitulation of the certification marking is detailed in the "Atex" section, on the next page, drawing numbers: 72562, 76180, 76801, 76855, 77320, 77326, and 79132.

10. The characteristics of the equipment shall be detailed e.g. electrical, pressure, and voltage parameters.

The manufacturer should note that, on being put into service, the equipment must be accompanied by a translation of the instructions in the language or languages of the country in which the equipment is to be used and by the instructions in the original language.

REA-70 72074 and REA-70L 75980 Electrostatic Applicators and ATEX Product Marking

Definitions

Ex Certificate Number: Sira 08ATEX5040X

Sira = Notified Body performing EC-type examination

08 = Year of certification

ATEX = Reference to ATEX Directive

5 = Protection Concept Code (code 5 is titled Encapsulation)

040 = Document serial number

X = Special conditions for safe use apply

Special conditions for safe use: The REA-70 72074 and REA-70L 75980 Electrostatic Applicators shall only be used with associated 75983-02, 76580-XX, and 76789-XX Low Voltage Control Units.

Product Marking



Ex = Specific marking of explosive protection

II = Equipment Group hazardous area characteristics

2 = Equipment Category

G = Type of explosive atmosphere (gases, vapors, or mists)

EEx 0.24mJ = The REA-70 72074 and REA-70L 75980 Applicators are suitable for use in automatic spraying installations complying with EN 50 050 as they are a Type A class with a discharge energy limit of 0.24mJ.

Label 72562

ITW Ransburg, Angola, IN, USA		CONTROL UNIT/POWER SUPPLY	
Electrostatic Systems		PART No.	SERIAL No.
WARNING FAILURE TO OBSERVE THE FOLLOWING PRECAUTIONS MAY RESULT IN AN ELECTRICAL DISCHARGE CAPABLE OF STARTING A FIRE.		VOLTS 115/220	"C"
1. THE ARTICLE BEING COATED MUST BE GROUNDED.		HERTZ 50/60	"D"
2. ALL OTHER ELECTRICALLY CONDUCTING OBJECTS WITHIN ABOUT TEN FEET OF THE OPERATING SPRAY GUN MUST BE GROUNDED.		OUTPUT VOLTAGE "E"	"E"
3. THIS CONTROL UNIT/POWER SUPPLY MUST BE INTERLOCKED WITH THE SPRAY BOOTH VENTILATORS SO AS TO PREVENT OPERATION OF THE POWER SUPPLY UNLESS VENTILATING FANS ARE IN OPERATION.		GUN MODEL "A" "B"	MAX PAINT PRESS MAX AIR PRESS
4. SERVICE WARNING-- ENCLOSURE PROTECTS AGAINST SHOCK AND INJURY. SERVICE TRAINING REQUIRED.		MAX APPROX 100 FT CBL LENGTH	100 PSI
5. KEEP POWER SUPPLY OUTSIDE THE HAZARDOUS AREA.		FLOW SWITCH	
6. DO NOT ATTEMPT OPERATION OR REPAIR BEFORE READING SERVICE MANUAL.		MAX AIR PRESS 100 PSI	FLOW PRESS 25 CFM @ 20 PSI
7. FOR ELECTROSTATIC PAINT FINISHING APPLICATIONS.			
		SIRA 08ATEX5040X	

Label 76180

ITW Ransburg	
Electrostatic Systems	
AVIATOR P/N:	75983-02
FOR:	REA 70 / REA 90
P/N:	75980 / 75979
MAX. VOLTAGE	65 kV / 85 kV
MAX. CURRENT	120 uA
MAX. PRESSURE	100 PSIG (6.8 BAR)
MAX. FLUID PRESSURE	100 PSIG (6.8 BAR)
MIN. FLUID RESISTANCE	0.10 MΩ
THIS UNIT MUST BE INTERLOCKED WITH THE SPRAY BOOTH VENTILATION AND CONVEYOR. EXPLOSION PROOF FOR USE IN CLASS I, DIVISON I, GROUP D ELECTROSTATIC FINISHING APPLICATIONS.	
SIRA 08ATEX5040X	

Label 76801

APPROVED FOR ELECTRO. FIN. APPL. CL. I, GP. D, SPRAY MATL. AIR ATOMIZING SYSTEM WHICH CONSISTS OF THE FOLLOWING: REA 70 MANUAL	
75980S(or L)-36(50, 75, 100); 2(or 4); 1 (or 2); 1(or 2);	
76789-01; 04(or 05-20) LOW VOLTAGE POWER SUPPLY	
78084-36(or 50, 75, 100) LOW VOLTAGE CABLE	
OR	
REA 90 MANUAL	
75979S(or L)-36(50, 75, 100); 2(or 4); 1; 1(or 2);	
76789-07; 04(or 05-20) LOW VOLTAGE POWER SUPPLY	
78084-36(or 50, 75, 100) LOW VOLTAGE CABLE	
OR	
REA IV MANUAL	
70404S(or L)-36(50, 75, 100); 2(or 4); 1; 1(or 2);	
77046-10 (or 11); 04(or 05-20) HIGH VOLTAGE POWER SUPPLY	
76298 LOW VOLTAGE CABLE, 76300 HV POWER SUPPLY,	
LREA4002-36(or 50, 75, 100) HIGH VOLTAGE CABLE	
FOR USE WITH ALL OF THE FOLLOWING:	
HOSES-14614-36(50, 75, 100)AIR, 14615-36(50, 75, 100)FLUID	
FAN CONTROLS- 72118-00 PUSH-PULL, 70966-00 LOCKING	
FLUID HOSES-77821-04(10 OR 25), 77822-04(10 OR 25)	
COILED FLUID TUBE 75228-01 COVER GC-100	
SIRA 08ATEX5040X	

Label 76855

APPROVED FOR ELECTRO. FIN. APPL. CL. I, GP. D, SPRAY MATL. AIR ATOMIZING SYSTEM WHICH CONSISTS OF THE FOLLOWING: REA 70 MANUAL	
72074S(L)-36(50,75,100); 2(4); 1; 1(2) APPLICATOR	
76580-1, 1(2), 0, 0(1), 1(2,3) LOW VOLTAGE POWER SUPPLY	
78084-36(50,75,100) LOW VOLTAGE CABLE	
14614-36(50,75,100) AIR HOSE	
14615-36(50,75,100) FLUID HOSE	
75228-11(12,13) COILED FLUID TUBE	
72118-00 PUSH-PULL FAN CONTROL	
70966-00 LOCKING FAN CONTROL	
77821-04(10,25) or 77822-04(10,25) FLUID HOSE	
GC-100 DISPOSABLE COVER	
SIRA 08ATEX5040X	

Label 777320

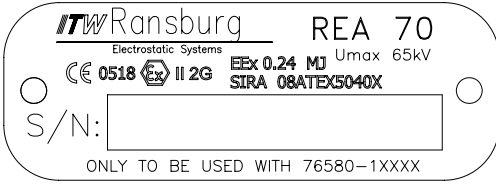

Label 777326

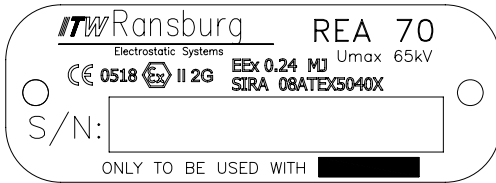

Label 79132

APPROVED FOR ELECTRO. FIN. APPL. CL. I, GP. D,
 SPRAY MATL. AIR ATOMIZING SYSTEM WHICH CONSISTS
 OF THE FOLLOWING:
 REA70, REA90 AND M90 MANUAL APPLICATORS

75980S(L)-36(50,75,99,200), 2(4), 1, 1(2) APPLICATOR
 75979S(L)-36(50,75,99), 2(4), 1, 1(2) APPLICATOR
 77073-37(51,76,101), 01(02) APPLICATOR

FOR USE WITH THE FOLLOWING APPLICABLE EQUIPMENT:

75983-02 LOW VOLTAGE POWER SUPPLY
 78085-36(50,75,100) LOW VOLTAGE CABLE
 14614-36(50,75,100) AIR HOSE
 74187-36(50,75,100) AIR HOSE
 14615-36(50,75,100) FLUID HOSE
 7994-36(50,75,100) FLUID HOSE
 72118-00 PUSH-PULL FAN CONTROL
 70966-00 LOCKING FAN CONTROL
 75228-01(02,03,11,12,13) COILED FLUID TUBE
 77821-04(10,25) FLUID HOSE
 77822-04(10,25) FLUID HOSE
 GC-100 DISPOSABLE COVER

APPROVED

SIRA 08ATEX5040X

NOTES

NOTES

INTRODUCTION

GENERAL DESCRIPTION

The REA process is an air-atomized method for electrostatically applying coatings to objects. The REA applicator system (technology) applies a high voltage DC charge to the applicator electrode, creating an electrostatic field between the atomizer and the target object.

The **REA-70 or REA-70L Delta Electrostatic Spray Applicators** (see Figures 1 and 2) applies a -65 kV DC charge to the coating materials at the point of atomization. This electrostatic charge allows a more efficient, uniform application of coating material to the front, edges, sides, and back of products. It is highly suitable for applying coatings to a variety of surface configurations: large targets, small parts, tubular wares, concave and recessed parts, etc. Because it is a grounded fluid system, it is highly suitable for applying a wide range of solvent reduced coatings such as enamels, lacquers, epoxies, etc.

The REA-70 and REA-70L electrostatic spray applicators are transformable between air spray and HVLP spray technology. The REA-70 is designed for use as a conventional air spray (high-pressure) or high volume/low-pressure (HVLP) air spray to atomize the coating material. By changing a select few parts, the applicator may be transformed to be operated in either spray mode. (See "Spray Technology Conversion Procedure" in the "Installation" section for details.)

A regulated pressure fluid system delivers coating material to the atomizer. At the time of triggering the applicator, fan and atomization air is introduced, which atomizes the coating material into a spray mist. The atomized spray particles under the influence of the electrostatic field become electrically charged. The charged particles are attracted to, and deposited on, the target object. The forces between the charged particles and the

grounded target are sufficient to turn most normal overspray around and deposit it on the back surface of the target. Therefore, a high percentage of the coating is deposited on the target.

One of the many features of the REA applicator system is that the electrical energy, which is available from the resistive charging electrode, is limited to the optimum level of safety and efficiency.

This system is incapable of releasing sufficient electrical or thermal energy during normal operating conditions to cause ignition of specific hazardous materials in their most easily ignited concentrations in air (see NFPA-33).

The control unit provides low voltage output to the applicator and contains controls for AC on/off, high voltage adjust, kV and micro amp meter.

As the applicator electrode approaches ground, the control unit and applicator circuitry cause the high voltage and current to "fold back" and decrease towards zero.

REA-70 WITH AVIATOR™

The REA-70 may be used with the AVIATOR power generator in hazardous locations. This equipment meets Class 1, Division 1, and Group D hazardous location requirements. This allows moving the REA-70 power source inside most spray booths or areas where the standard control unit may not be conveniently located. Examples are airplane hangars, etc.

SPECIFICATIONS

REA-70 SOLVENT BASE
 - STANDARD (72074)
 - AVIATOR/MGS (75980)

Environmental / Physical

Applicator Length: 9.5-inches (_____)

Weight: 25 ounces (_____)

Hose & Cable

Lengths: 36 ft. (Optional: 50, 75, and 100 ft.)

Atomizer

Assembly (Std): 4907-45, 4904-65R
 Air Spray
 75601-00, 75600-01 HVLP

Electrical

Operating Voltage: 65 kV DC (-) maximum

Current Output: 120 microamperes
 maximum (foldback)

Paint Resistance *: .1 MΩ to ∞

Part Sprayability: Determine sprayability of part to be coated using 76652 Test Equipment

Mechanical

Fluid Flow

Capacity: 1000 cc/minute**

Operating Pressure (Air Spray)

Fluid: 0-100 psi

Air: 0-100 psi

Consumption: 16 CFM @ 50 psi

Operating Pressure (HVLP Spray)

Fluid: 0-100 psi

Air: 0-100 psi

Consumption: 22 CFM @ 50 psi
 (handle input) for 10 psi
 nozzle output

* (Use Model No. 76652, Test Equipment)

** This reflects the maximum fluid volume the applicator can deliver. The maximum spray volume that can be atomized depends on fluid rheology, spray technology, and finish quality required.

APPLICATOR:
REA-70 (72074S)
REA-70L (72074L)

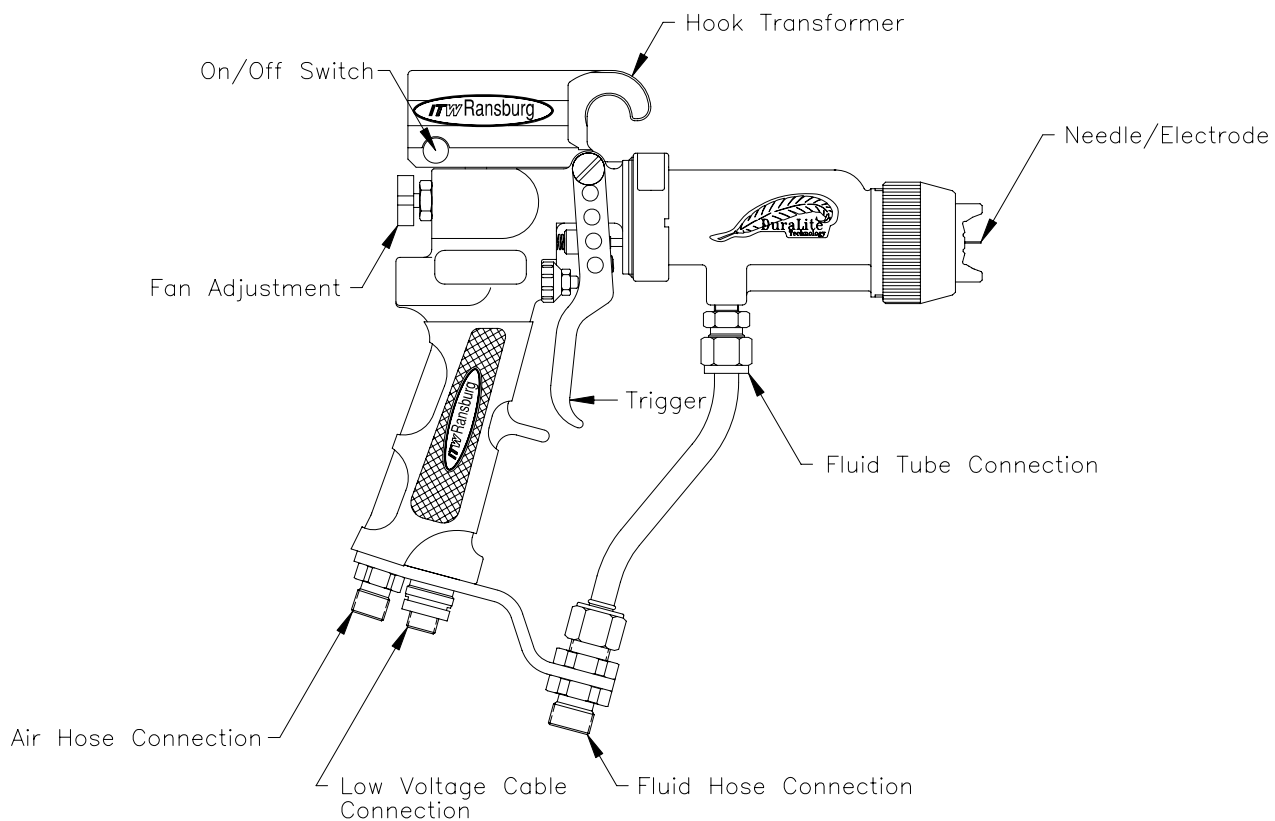

Figure 1: REA-70 and REA-70L Standard Electrostatic Spray Applicator Features

APPLICATOR:
REA-70 AVIATOR (75980S)
REA-70L AVIATOR (75980L)

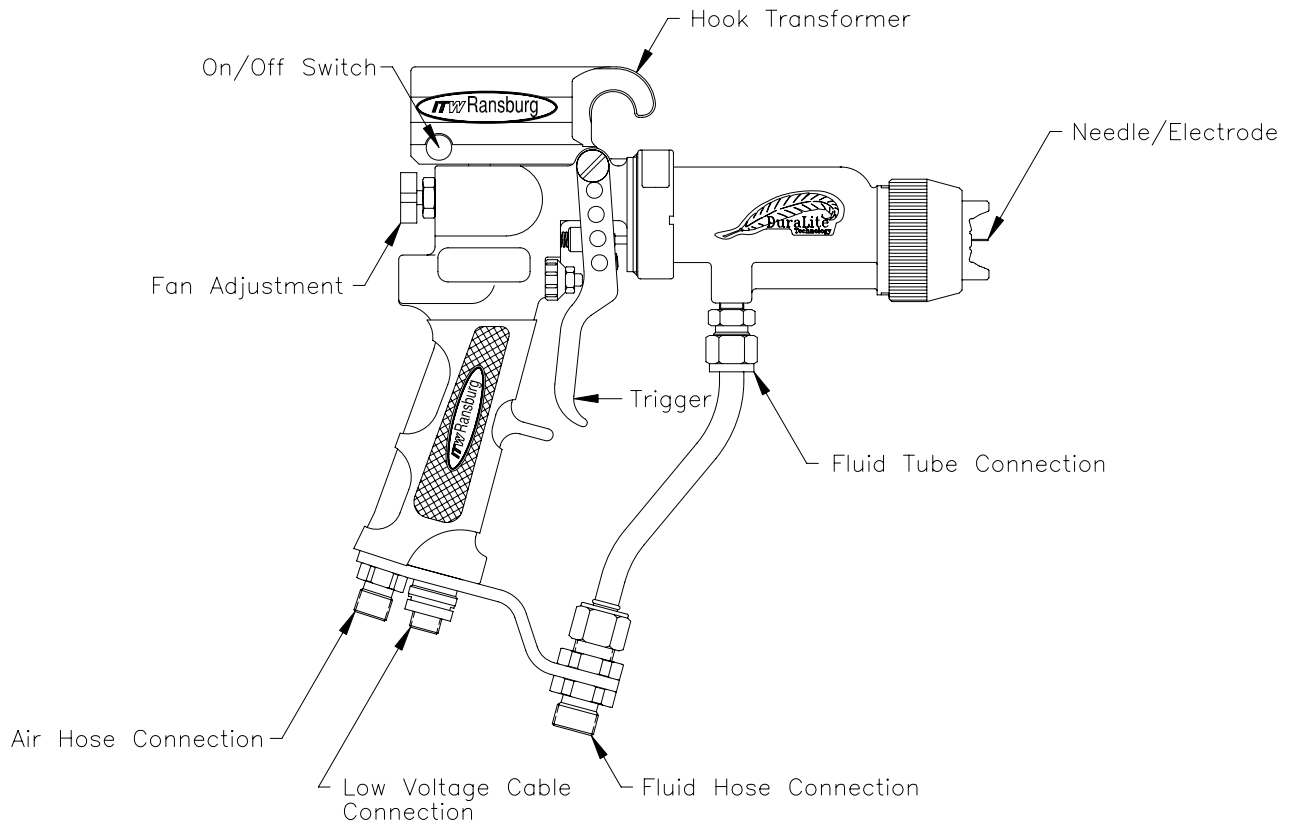

Figure 2: REA-70 and REA-70L Aviator/MGS Electrostatic Spray Applicator Features

INSTALLATION

72074 STANDARD SOLVENT BASE AND 75980 AVIATOR/MGS SOLVENT BASE INSTALLATION

⚠ WARNING

- ▶ Installation of the equipment **MUST** be in compliance with all Federal, State, and Local Codes. Prior to installation, all personnel should read and understand the NFPA-33, OSHA, and ITW Ransburg literature "Electrostatic Safety Information from ITW Ransburg".

⚠ WARNING

- ▶ **NEVER** wrap the applicator, associated valves and tubing, and supporting hardware in plastic to keep it clean. A surface charge may build up on the plastic surface and discharge to the nearest grounded object. Efficiency of the applicator will also be reduced and damage or failure of the applicator components may occur. **WRAPPING THE APPLICATOR IN PLASTIC WILL VOID WARRANTY.**

Location of Control Unit (Non-AVIATOR Units)

Install the low voltage control unit at least 3 feet (0.9m) outside the spray area and/or in accordance with federal, state, and local codes. Refer to the low voltage control unit manual for mounting details. The control unit can be wired through conduit or with a line cord depending upon application requirements and codes.

The control unit **MAY** be connected through conduit to an explosion-proof switch (to turn high voltage on and off) and explosion-proof indicator light (indicates status of control unit) within the hazardous area for the convenience of the operator.

Location of Control Unit (AVIATOR Units)

The AVIATOR may be located within the hazardous area. It may be mounted on a booth wall, pump cart, or other suitable places. Refer to the AVIATOR Power Generator manual for details on its installation.

The air supply to the AVIATOR Power Generator must be interlocked with the exhaust air for the spray area. If a conveyor system is used, then the air supply must be interlocked with it also.

Routing of Low Voltage Cable

Position the spray applicator in the spray area and route the low voltage cable to the control unit. The cable should be routed so that it is not damaged by foot and vehicle traffic and also so that it is not close to areas of high temperature (129°F+). The operator should have free movement of the applicator and all bend radius of the cable should not be less than 6-inches (15 cm). Connect the low voltage cable to the control unit and hand tighten the retaining nut. If during the routing of the low voltage cable it is required to remove it from the spray applicator, care should be taken when reinstalling it back that the retaining nut is wrench tight and the nut cannot be removed by hand.

⚠ CAUTION

- ▶ Do **NOT** overtighten the low voltage connection at the applicator. The plastic parts could be damaged.

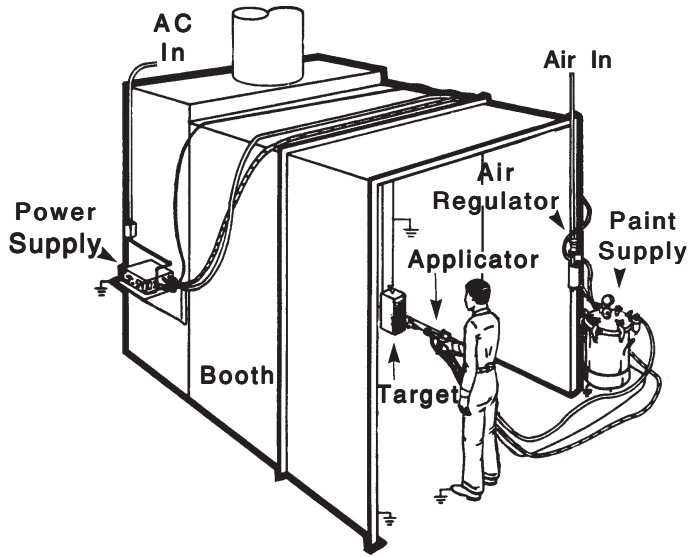

Figure 3: Typical REA Applicator Installation

! WARNING

► When installing the AVIATOR Power Generator, the air supply to the generator must be interlocked with the booth exhaust air and the conveyor system.

FILTERS

1. Install an air filter assembly on the air inlet of the control unit. Screw the fitting into the filter inlet. The filter **MUST** be installed with the arrow pointing in the direction of flow. Refer to the appropriate filter assembly manual for installation instructions.

! CAUTION

► An air filter **MUST** be installed to permit proper functioning of the air flow switch inside the control unit.

! WARNING

► The electrical discharge that is available from the charging electrode must not exceed 0.25 mJ of energy. To achieve this limit, any flow of energy from the paint supply through the paint line to the applicator electrode must be prevented by grounding the paint line at the applicator handle.

Verify that the applicator handle is actually grounded before operating it! This is done with a fully connected and operational system, by placing one lead of an ohmmeter to the handle and the other to the building electrical ground (cold water pipe, building structure, steel, etc.). This reading should be essentially zero.

If a greater reading is obtained, check that the control unit is grounded. See the control unit manual for grounding procedure.

2. ITW Ransburg recommends that a fluid filter be installed at the output of the fluid supply (pressure pot, pump, circulating system, etc.). It is the end users responsibility to install a filter that meets their system's requirements.

FLUID HOSE FITTING INSTALLATION

(Refer to Figure 4)

ITW Ransburg supplies a standard 36-foot hose. Optional hose lengths of 50, 75, 100, and 150 feet are available. To meet various length requirements, the hose fitting on one end has not been attached. Determine the hose length that is needed and cut the hose off squarely. Attach the other fitting as follows.

1. Lightly lubricate all threaded areas with dielectric grease or petroleum jelly.
2. Screw the ferrule counter-clockwise onto hose until it bottoms. Then screw clockwise approximately 1/8-inch.

NOTE

► The union stem will not seat if the hose is bottomed against the ferrule.

3. Install the nut over the union stem, lubricate the stem, and start the stem into the hose, using care not to catch the hose lining with the stem tip.

4. Using a 3/16-inch Allen wrench, screw the union stem into the hose until it bottoms against the ferrule.

5. Connect one end of the hose to the fluid fitting at the bottom of the applicator handle and the other end to the appropriate fluid source.

AIR HOSE FITTING INSTALLATION

(Refer to Figure 4)

ITW Ransburg supplies a standard 36-foot hose. Optional hose lengths of 50, 75, 100, and 150 feet are available. To meet various length requirements, the hose fitting on one end has not been attached. Determine the hose length that is needed and cut the hose off squarely. Attach the other fitting using the same procedure used for the fluid hose fitting installation.

PAINT PREPARATION

A proper paint mixture is essential to electrostatic operation. Paint test equipment may be obtained through your ITW Ransburg representative. Reference Technical Manual "Paint Related Information for REA, Vector, REM, and M90 Applicators" for paint formulation information. For further paint formulation and testing procedures, consult your ITW Ransburg representative and/or your paint supplier.

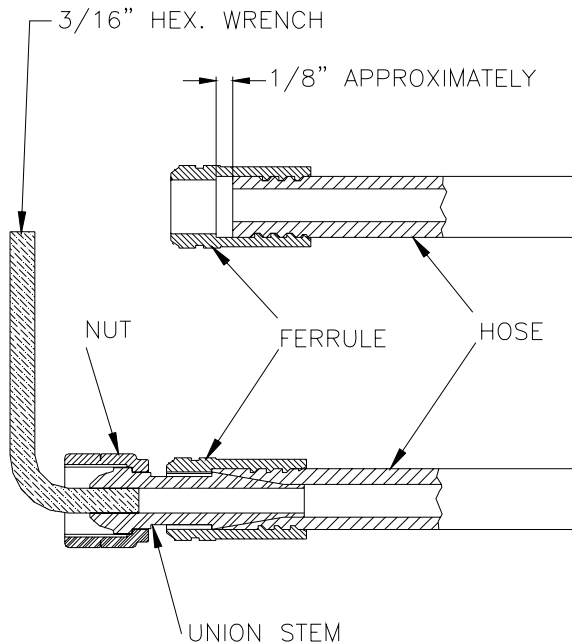



Figure 4: Fluid Hose Assembly

SPRAY TECHNOLOGY CONVERSION PROCEDURE

1. Remove the existing retaining ring and air nozzle from the applicator.
2. Using the special multi-purpose applicator wrench, remove the fluid nozzle by turning counter-clockwise to loosen.

 CAUTION
<ul style="list-style-type: none"> ▶ To avoid damage to the fluid nozzle and electrode, the paint pressure and trigger return spring tension MUST be released by triggering the applicator while removing or installing the fluid nozzle. <p>The applicator barrel MUST be tilted front down to remove the fluid nozzle. Failure to do so may allow paint to enter the air passages, thereby reducing airflow and damaging the applicator barrel cascade. Applicators may be flushed in lieu of tilting. However, they must be either flushed or tilted down during nozzle removal!</p>

3. With a blade screwdriver, remove the pressure reducer from the barrel by unscrewing it counter-clockwise.
4. Install the new pressure reducer.
5. Install appropriate fluid nozzle, gently tightening into place using the special multi-purpose applicator wrench.
6. Reinstall appropriate air cap and retaining ring. See Figure 5 for proper combination of air caps, fluid nozzles, and pressure reducers.
7. Remove fan control valve assembly and replace with appropriate fan control valve assembly according to spray technology being used. (Reference Figure 5 for proper fan control valve.)

NOTE

- ▶ Control knob of fan control valve must be adjusted to the rear most position to avoid valve and/or seat damage.

NOTE

- ▶ To avoid cross threading the plastic handle, install the fan control valve by hand. Once properly aligned, complete the assembly procedure using a suitable wrench.

NOTE

- ▶ Proper selection of a fan control valve is necessary to meet certain state codes requiring 10 psi maximum air pressure at the air cap when using HVLP technology. Special gauges and test nozzles are available to confirm the pressure output. (See "Service Kits" in the "Parts Identification" section for these parts.)

SPRAY PATTERN ADJUSTMENT

The spray pattern of fan atomizers is adjustable from a small circle to an elongated oval, approximately 10 to 18-inches of usable pattern when sprayed from a target distance of 8 to 12-inches. The swirl atomizer assemblies produce a round pattern from 5 to 9-inches in diameter. The fan control knob provides control of the pattern shaping air. Counter-clockwise expands the pattern and clockwise reduces it. To change the spray pattern axis of fan atomizers from horizontal to vertical, loosen the retainer ring, rotate the air cap clockwise to the desired position, and gently tighten the ring.

CAUTION

- ▶ A counter-clockwise turn of the air cap may loosen the fluid nozzle and cause air to get into the paint or paint to cross over into the air passages.

APPLICATOR TO TARGET DISTANCE

Hold the applicator 6 to 12-inches maximum from the target for best operation (higher transfer efficiency will be achieved at the closer target distance). Trigger the applicator fully to operate.

NOTE

- ▶ See ITW Ransburg Bulletin "REA Applicator Spray Techniques".

NOTES

NOTES

AIR CAP / FLUID NOZZLE SELECTION CHART - Air Spray (Fan Control Valve 18851-01)				
Air Cap Part #	Fluid Nozzle Part #	Orifice ID	Separate Retaining Ring	Pressure Reducer (Black)
4904-65R	4907-44	0.055	73569-00	74963-02
4904-65R	4907-45	0.070	73569-00	74963-02
4904-65R	4907-46	0.042	73569-00	74963-02
4904-65R	4907-47	0.028	73569-00	74963-02
4904-65R	4907-48	0.047	73569-00	74963-02
4904-63	4907-44	0.055	73569-00	74963-02
4904-63	4907-45	0.070	73569-00	74963-02
4904-63	4907-46	0.042	73569-00	74963-02
4904-63	4907-47	0.028	73569-00	74963-02
4904-63	4907-48	0.047	73569-00	74963-02
4904-98	4907-44	0.055	73569-00	74963-02
4904-98	4907-45	0.070	73569-00	74963-02
4904-98	4907-46	0.042	73569-00	74963-02
4904-98	4907-47	0.028	73569-00	74963-02
4904-98	4907-48	0.047	73569-00	74963-02

AIR CAP / FLUID NOZZLE SELECTION CHART - Round Spray (Fan Control Valve 18851-01)				
Air Cap Part #	Fluid Nozzle Part #	Orifice ID	Separate Retaining Ring	Pressure Reducer (Black)
70899-00	70898-00	Swirl*	4903-00	74963-02
LREA0002	LREA0003	Round*	73569-00	74963-02

* Both round and swirl nozzles are limited to approximately 300 cc (10 oz) maximum fluid delivery per minute.

AIR CAP / FLUID NOZZLE SELECTION CHART - HVLP Spray (Fan Control Valve 75133-00)				
Air Cap Part #	Fluid Nozzle Part #	Orifice ID	Separate Retaining Ring	Pressure Reducer (Black)
75601-00	75600-01	0.055	73569-00	74963-03
75756-00	75600-02	0.070	73569-00	74963-03
75756-00	75600-03	0.086	73569-00	74963-03

AIR CAP / FLUID NOZZLE PERFORMANCE CHART

Fluid Nozzle Part #	Orifice ID (in/mm)	Fluid Delivery* (ml/min)	Spray Type	Air Consumption** (SCFM/SCMM)	Air Pressure (psi/bars)	Air Cap	Pattern Size*** (inches)	Pressure Reducer	Applicators
4907-44	.055/1.4	600	Air Spray	14.8/.40	22/1.5	4904-65R	15±1/2	Black	REA-III, IV, 70, & 90
4907-44	.055/1.4	300	Air Spray	13.5/.38	37/2.6	4904-63	9-1/2±1	Black	
75600-01	.055/1.4	318	HVLP Spray	23.8/.81	10/.69	75601-00	10-3/4±1	White	

* Material: Lacquer, 18 Sec. No. 4 Ford Cup @ 72°F. Results are material dependent.

** Air Flow @ Air Pressure noted in next column.

*** Patterns at 8-inch target distance.

MAINTENANCE

SUITABLE SOLVENTS FOR CLEANING REA-70 APPLICATORS

When cleaning the REA-70 applicator, a suitable solvent for cleaning depends on the part(s) of the applicator to be cleaned and the material that needs to be removed. ITW Ransburg recommends that all exterior cleaning be done with non-polar solvents to prevent a conductive residue on critical components. We also understand that some of these solvents do not always meet the cleaning needs of some materials. If conductive polar solvents are used to clean the applicator components, all residue must be removed using a non-conductive non-polar solvent (i.e. high flash naphtha). If there are any questions as to what solvents are best for cleaning, contact your local ITW Ransburg distributor and/or your paint supplier.

The REA-70 applicator, air hoses, fluid hose, and low voltage cable assemblies should not be submerged or soaked in solvent. However, the outer surfaces of these items can be wiped with a suitable solvent. When the applicator is disassembled into individual components, some of these items may be soaked in a suitable cleaning solvent. The items that cannot be soaked are noted throughout this manual. All o-ring and electrical components **cannot** be cleaned or soaked in any solvents.

WARNING

- ▶ The user **MUST** read and be familiar with the safety instructions in this manual.
- ▶ If compressed air is used in cleaning, **REMEMBER** that high pressure air can be dangerous and should **NEVER** be used against the body. It can blind, deafen, and may even penetrate the skin. If used for cleaning equipment, the user should wear safety glasses.
- ▶ **ALWAYS** turn the control unit's power off or the supply air to the AVIATOR off prior to cleaning and servicing the equipment.
- ▶ Be **SURE** the power is **OFF** and the system is grounded before using solvent to clean **ANY** equipment.
- ▶ **DO NOT** operate a faulty applicator!
- ▶ When using cleaning solvent, standard health and safety precautions should apply.
- ▶ Cleaning of the exterior surface of the applicator should be done with non-polar solvents. If cleaning requires the use of polar solvents, the applicator should be wiped down with non-polar solvent prior to going back into use. Using polar solvents will leave a semi-conductive film on the surface of the applicator that will effect efficiency of the applicator and cause damage to the components.

ROUTINE SCHEDULE

Follow these maintenance steps to extend the life of the applicator and ensure efficient operation.

Several Times Daily

- Turn the control unit power to OFF!
- Inspect the air cap for paint accumulation. Clean as frequently as necessary with a soft bristled brush and a suitable solvent.

! CAUTION
<p>► NEVER remove the fluid nozzle assembly while paint is in the applicator or paint may enter into the air passages. Clogged or restricted air passages will cause poor atomization and/or electrical shorting. Air passages that are clogged with conductive material can lead to excessive current output levels and consequent low operating voltage or long-term electrical damage. Before undertaking any atomizer maintenance procedure, see "Atomizer Assembly Cleaning Procedure".</p> <p>The applicator barrel MUST be tilted front down to remove the fluid nozzle. Failure to do so may allow paint to enter the air passages, thereby reducing airflow and damaging the applicator barrel/cascade. Applicators may be flushed in lieu of tilting. However, they must be either flushed or tilted down during nozzle removal!</p>

- Clean all insulating surfaces in the system. Remove paint accumulation from the exterior of the applicator and low voltage cable with a solvent dampened cloth.

! CAUTION
<p>► NEVER soak or submerge the electrical components of the applicator, i.e., barrel, hook, transformer or cable. Damage and failure may occur.</p>

Daily (or at start of each shift)

- Verify that ALL solvent safety containers are grounded!
- Check within 20 feet of the point of operation (of the applicator) and remove or ground ALL loose or ungrounded objects.
- Inspect workholders for accumulated coating materials (and remove such accumulations).
- Check that atomizer assembly is clean and undamaged.
- Straighten the applicator electrode if necessary.

! CAUTION
<p>► When straightening the electrode be careful not to distort fluid nozzle orifice.</p>

- Clean the fluid filter, if used.
- Turn the control unit power ON. Its green pilot should light.
- Run a current/voltage output test.

Electrical Current Output Test

1. Turn the paint supply OFF.
2. Trigger the applicator (high voltage ON).
3. Slowly approach the applicator electrode to any grounded object and make contact.
4. Monitor the current output reading on the voltage supply meter as the applicator approaches ground:

For Standard/MGS solvent units:

- a.) kV should fold back and be near zero at contact.
- b.) Current should increase to near 90 μ a and fold back to 20 μ a or less at contact.

For AVIATOR units:

- a.) Transformer light should become very dim in illumination power.

If the reading is outside of the acceptable range, do NOT use the applicator until the problem has been corrected (see "Troubleshooting Guide" in the "Maintenance" section).

- 5. Release the trigger (high voltage OFF) and turn the control unit power OFF.

Shutdown (or at end of each shift)

1. Turn the control unit power OFF / turn OFF supply air to AVIATOR generator.
2. Turn the paint supply OFF.
3. Turn the atomizing and fan air OFF.
4. Wipe the applicator, cable, and hoses with a rag and a suitable cleaning solvent.
5. Flush the lines and allow the solvent to remain in the lines unpressured (see "Flushing Procedures" in the "Maintenance" section).

NOTE

► If production down-time is to be short, the fluid lines may not require flushing, depending on the coating material being used. If the solids in the material settle slowly, the lines will not need to be flushed as soon after shutdown as with fast settling solids. The paint being used and the length of downtime will determine the need for flushing. Metallic paint and primer will require flushing sooner than other types of coating materials.

CAUTION

- If the coating material is fast settling and the fluid lines are not flushed soon enough, the internal passages may become clogged. This can lead to excessive downtime for repair.

Weekly

- Check the entire system for damage, leaks, and paint accumulation.
- Clean the atomizer assembly.

APPLICATOR ASSEMBLY CLEANING PROCEDURE

Routine Cleaning Equipment Needed

- An appropriate solvent
- A solvent safety container (grounded)
- A small soft-bristled brush
- The ITW Ransburg special multi-purpose wrench (19749-00)

CAUTION

- To avoid damage to the fluid nozzle, needle/electrode, the paint pressure **MUST** be released by triggering the applicator prior to removing the tip.
- The applicator barrel **MUST** be tilted front down to remove the fluid nozzle. Failure to do so may allow paint to enter the air passages, thereby reducing airflow and damaging the applicator barrel/cascade. Applicators may be flushed in lieu of tilting. However, they must be either flushed or tilted down during nozzle removal!
- The control unit power **MUST** be off when removing the nozzles and/or during any applicator maintenance.

! CAUTION

- ▶ When installing or removing the fluid nozzle, the applicator **MUST** be triggered. Failure to do so may cause damage to the electrode or fluid nozzle. Such damage can result in fluid leaks around the sealing area of these components.
- ▶ Using any tool other than the ITW Ransburg Multi-Purpose Wrench (19749-00) to remove or install the fluid nozzle may cause damage.

! WARNING

- ▶ Any broken or damaged components should be replaced. Any damage to the applicator may result in **UNSAFE** operating conditions.

5. Clean the applicator and associated parts with a soft brush and suitable solvent.

! CAUTION

- ▶ Metal tools and wire brushes must **NEVER** be used. **NEVER** use a cleaning tool that is harder than the plastic parts. If a deposit cannot be removed with the solvent and a rag or the soft brush, soak the part in the solvent **ONLY** until the deposit can be removed! **NEVER** soak the applicator body, barrel, or hook transformer!

For efficient electrostatic operation, keep the applicator's exterior and low voltage cable free of paint accumulation. This prevents the loss of voltage to ground with a resultant reduction in transfer efficiency. Paint accumulation in and around the air cap nozzles will reduce atomization quality. Clean the air cap using clean solvent and a soft bristle brush as often as needed to ensure good atomization.

! WARNING

- ▶ **NEVER** wrap the applicator, associated valves and tubing, and supporting hardware in plastic to keep it clean. A surface charge may build up on the plastic surface and discharge to the nearest grounded object. Efficiency of the applicator will also be reduced and damage or failure of the applicator components may occur. **WRAPPING THE APPLICATOR IN PLASTIC WILL VOID WARRANTY.**

Proceed as follows:

1. Turn **OFF** the control unit power / turn **OFF** supply air to the AVIATOR power generator.
2. Release the trigger.
3. Turn the paint flow **OFF**.
4. See "Applicator Repair" in the "Maintenance" section for disassembly procedures.

FLUSHING PROCEDURES

1. Turn OFF the control unit power / turn OFF supply air to the AVIATOR power generator.
2. Turn the paint supply OFF.
3. Turn the atomizing air supply OFF.
4. Tilt the applicator down and trigger until it is clear of paint.
5. Connect the solvent supply.
6. Run solvent through the system until it runs clear.
7. Disconnect the solvent supply.
8. Trigger the applicator until it is clear of solvent. After the preceding steps are complete, the applicator is ready for color change, storage, or maintenance.

 CAUTION
<p>► Do NOT allow the fluid lines to stand empty without flushing first! This will cause dried paint flaking and clogging of the fluid lines, applicator passages, and/or nozzles.</p>

APPLICATOR REPAIR

All repairs should be made on a clean, flat surface. If a vise is used to hold parts during service or repair, DO NOT clamp onto plastic parts and always pad the vise jaws!

The following parts should be thoroughly packed with dielectric grease (LSCH0009-00) leaving NO air space or voids when assembling:

- All rubber o-rings (Teflon o-rings do not need lubrication)
- Needle Shaft Assembly 78627-05
- Packing Tube 18842-02
- Transformer/Hook Assembly 71202-XX
- Cartridge Assembly, Non-Adjustable 78626-00
- Air Valve Rod Assembly 79310-00

Apply sealant (7969-10) to the external threads of the following parts when assembling:

- Nut, Air Valve Retaining 78635-00
- Cap, Air Valve 79317-00
- Nut, Fan Valve Retaining 18851-01 / 75133-00
- Cap, Spring 77015-00

EQUIPMENT REQUIRED

- Special Multi-Purpose Wrench (19749-00)
- 3/32-inch Allen Wrench for Set Screws (2)
- 3/16-inch Allen Wrench for Hose Fittings
- Open End Wrenches: 15/16, 7/8 11/16, 9/16, 7/16, 3/4, 3/8, and 1/4-inch
- Screwdriver (blade)
- Dielectric Grease (LSCH0009-00)
- Sealant, medium strength (7969-10)
- Plastic or Wood Dowel Rod, 5/16-inch diameter

TO REMOVE THE APPLICATOR FROM THE WORK SITE

 CAUTION
<ul style="list-style-type: none"> ▶ ALWAYS remove the applicator from the work site for service or repair! ▶ DO NOT use any silicone lubricants in order to avoid paint defects.

3. With a wrench, lock the air fitting in place and loosen the air hose nut using a second wrench. Completely unscrew the nut and remove the air hose assembly.

NOTE
<ul style="list-style-type: none"> ▶ If the low voltage cable is to be replaced, see "Low Voltage Cable Replacement" in the "Maintenance" section.

Solvent Base Applicators (Refer to Figure 5)

1. Flush the applicator. (Refer to "Flushing Procedures".)
2. With a wrench, loosen and unscrew the fluid hose nut. Remove the fluid hose assembly.

4. Loosen the low voltage cable nut from the plug assembly with a wrench and unscrew the nut by hand. Remove the low voltage cable by pulling it from the low voltage cable plug assembly.

5. Remove the applicator from the work site.

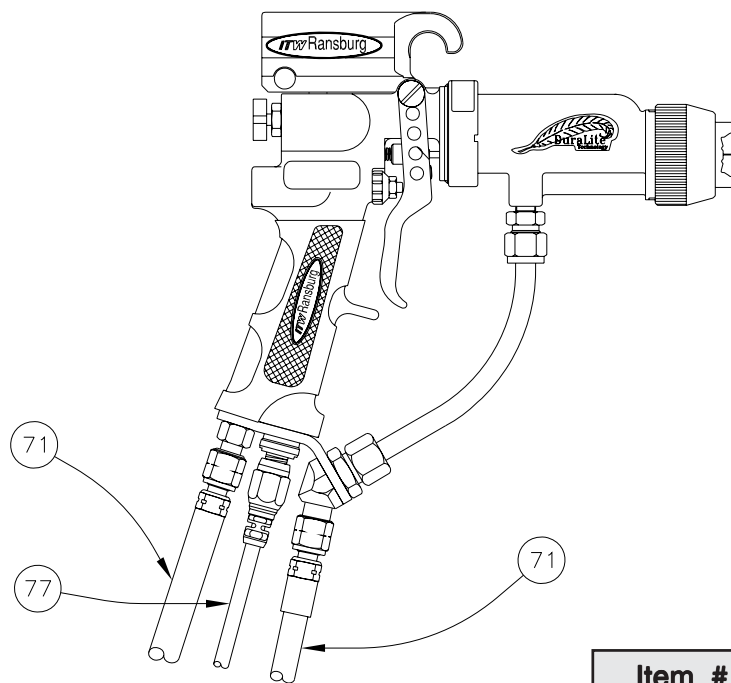

Item #	Description
71	Fluid Hose Assembly
71	Air Hose Assembly
77	Low Voltage Cable

Figure 5: Solvent Base Applicator Connections

AIR CAP

(Refer to Figure 6)

Removal

1. While holding the air cap in place with one hand, loosen the retaining nut using the other hand.
2. Unscrew the retaining nut completely and remove the air cap.

Cleaning and Inspection

1. Use a suitable solvent to clean the air cap. (Refer to "Suitable Solvents for Cleaning REA-70 Applicators" in the "Maintenance" section.)
2. Examine the air cap for damage to the air horns, face, and any air passages. If any of these areas are damaged or worn, the air cap should be replaced.

Reinstall

1. Check the fluid nozzle to ensure that it is tightly screwed into the barrel.
2. Place the air cap over the electrode wire of the needle/electrode and set it onto the fluid nozzle.
3. Place the retaining nut over the air cap and begin screwing it onto the barrel.
4. Before securing the retainer nut to the barrel, position the air cap for the desired spray pattern position.

FLUID NOZZLE

(Refer to Figure 6)

Removal

1. Remove the air cap from the applicator. (Refer to "Air Cap - Removal" in the "Maintenance" section.)
2. Tilt the applicator forward and pull the trigger to make sure that all fluid in the applicator is drained out.

CAUTION

- The applicator barrel **MUST** be tilted front down to remove the fluid nozzle. Failure to do so may allow paint to enter the air passages, thereby reducing airflow and damaging the applicator barrel. Applicators may be flushed in lieu of tilting. However, they **MUST** be either flushed or tilted during nozzle removal!

3. While holding the applicator assembly with the trigger pulled back, remove the fluid nozzle with the open-end of the special multi-purpose wrench.

NOTE

- To keep the needle/electrode from unscrewing from the needle shaft, the applicator's trigger should be actuated to pull the needle/electrode away from the fluid nozzle.

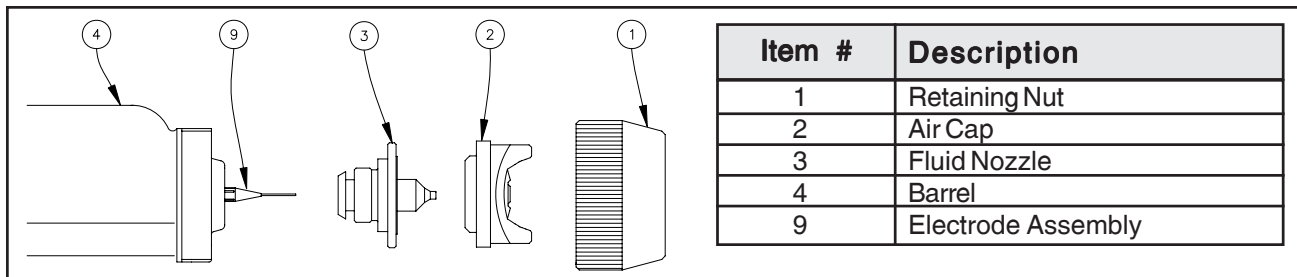

Figure 6: Air Cap, Fluid Nozzle, and Nut

Cleaning and Inspection

1. Use a suitable solvent to clean the fluid nozzle. (Refer to "Suitable Solvents for Cleaning REA-70 Applicators".)
2. Examine the fluid nozzle for damage to the air passages and the fluid nozzle tip. Also, examine the needle seat for damage or wear. If any damaged or any worn areas are found, the fluid nozzle must be replaced.

NOTE

- ▶ If the fluid nozzle is replaced, there is a good chance that the needle/electrode assembly will need to be replaced also. A worn needle/electrode assembly may not always seat well in a new fluid nozzle.

Reinstall

1. Check the needle/electrode tightness on the needle shaft. If it is loose, tighten it. (Refer to "Needle/Electrode" in the "Maintenance" section.)
2. With the applicator trigger actuated, place the fluid nozzle over the needle/electrode and screw it into the barrel by hand.
3. Tighten it using the special multi-purpose wrench.

NOTE

- ▶ DO NOT overtighten the fluid nozzle into the barrel. Doing so could damage or break the fluid nozzle or damage the thread of the barrel.

4. Install the air cap and retaining ring onto the applicator. (Refer to "Air Cap - Reinstall" in the "Maintenance" section.)

NEEDLE / ELECTRODE

Removal

1. Remove the air cap and fluid nozzle from the applicator assembly. (Refer to "Air Cap - Removal" and "Fluid Nozzle - Removal" in the "Maintenance" section.)
2. Secure the needle shaft at the rear of the barrel and unscrew the needle/electrode from the needle shaft.

Cleaning and Inspection

1. Use a suitable solvent to clean the needle/electrode. (Refer to "Suitable Solvents for Cleaning REA-70 Applicators".)
2. Examine the needle/electrode for damage or wear. Pay special attention to the area where the wire electrode extends from the main body. This is a sealing surface that seats inside the fluid nozzle. If there are signs of wear in this area, both the needle/electrode and fluid nozzle must be replaced.
3. An electrical check of the needle/electrode must be done prior to reinstalling it into the applicator assembly. (Refer to "Needle/Electrode Resistance Testing" in the "Maintenance" section.)

Reinstall

1. Secure the needle shaft at the rear of the barrel and screw the needle/electrode into place by hand.
2. Reinstall the fluid nozzle and air cap onto the barrel. (Refer to "Air Cap - Reinstall" and "Fluid Nozzle - Reinstall" in the "Maintenance" section.)

NEEDLE / ELECTRODE RESISTANCE TESTING

The electrical resistance of the needle/electrode should be tested periodically (typically on a weekly basis) or any time it is removed from the applicator.

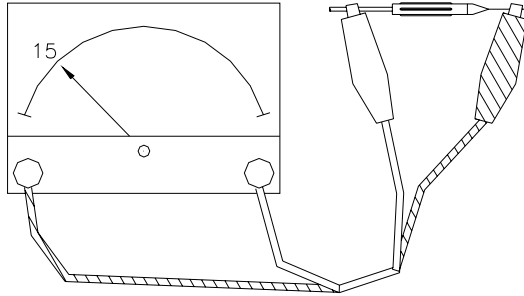

Figure 7: Testing Resistive Electrode

To Test

1. Install the needle/electrode onto the front end of an available needle shaft. Be sure that the needle/electrode is completely seated for proper contact between the metal shaft and the threaded insert of the needle/electrode.

2. Using a VOM meter that will read 15 megohms accurately, connect the first meter lead to the metal needle shaft and the second lead to the needle/electrode wire. The needle/electrode resistance should be 14.5 to 19 megohms (nominal 15 megohms at 9 volts or 11 to 17 megohms at 1000 volts). Needle/electrodes outside these ranges must be replaced.

BARREL ASSEMBLY

NOTE

- If during pretesting it is found that the cascade section of the barrel is bad, repair of barrel is not an option. The only course of action is to replace the barrel assembly.

Removal

1. While holding the air cap in place with one hand, loosen the retaining nut using the other hand.
2. Unscrew the retaining nut completely and remove the air cap.
3. Using a flat head screwdriver, remove the two (2) shoulder screws that retain the trigger to the applicator handle.
4. While holding the grounding spring (located under the trigger and over the air valve stem) back toward the handle, remove the trigger from the applicator handle. Remove the grounding spring from the air valve stem.
5. Using an adjustable wrench, unscrew the fluid tube connector from the barrel and slide it down the fluid tube.
6. Use the special multi-purpose wrench to loosen the retaining nut that secures the barrel to the applicator handle. After unscrewing the retaining ring, slide it forward onto the barrel.
7. Hold the applicator handle and fluid tube so the barrel points downward. With the other hand, pull the barrel forward to separate it from the handle. Once the barrel has cleared of the handle, remove the spring from the spring retainer and set it aside. If the fluid tube does not come loose from the barrel, rotate the barrel back and forth on the axis of the fluid tube until it comes loose.
8. There is no need to remove the retaining ring or nut from the barrel unless they are damaged. If they are to be replaced, lift one end of retaining ring over the captive ridge and spiral it off the end of the barrel. Then the retaining nut can be removed.

CAUTION

- Use care in removing the retaining ring. If it is spread too much it could break.

Disassembly

1. Remove the trigger adjustment nut and spring retainer from the needle shaft using two 3/8-inch open-end wrenches.

2. Position the barrel so the front is facing down. Using the small spanner tool on the special multi-purpose wrench, unscrew the packing nut from the rear of the barrel by turning it counter-clockwise.

3. Holding the barrel in one hand and with a firm pull, remove the needle shaft assembly from the packing chamber of the barrel. The trigger adjustment nut can be reinstalled for additional grip. If the needle shaft will not pull out of the barrel, use the following procedure:

- a.) Remove the needle/electrode from the needle shaft.
- b.) Pull the needle shaft from the rear of the barrel.
- c.) Place the barrel on a work bench. Holding the barrel in one hand, with the front pointing upward, push a 5/16-inch diameter wooden or plastic dowel through the center bore of the barrel. This should push the cartridge seal assembly out the rear of the barrel.

 CAUTION
<p>► During this operation, be CAREFUL that the interior surface of packing chamber is NOT damaged (marred or scratched)! This chamber is a seal area and the barrel/cascade assembly will have to be replaced if it is damaged.</p>

4. Remove the trigger adjustment nut if it was required when pulling the needle shaft from the barrel packing chamber. Then remove the packing nut, spacer, rear seal retainer sub-assembly, and packing tube from the rear of the needle shaft. The spring-loaded u-cup and o-ring can now be removed from the rear seal retainer.

NOTE

► If the spacer and seal retainer do not separate easily, wedge a knife blade between them and pry them apart.

5. Unscrew the needle/electrode from the front of the needle shaft.

6. Remove the cartridge seal assembly from the front of the needle shaft.

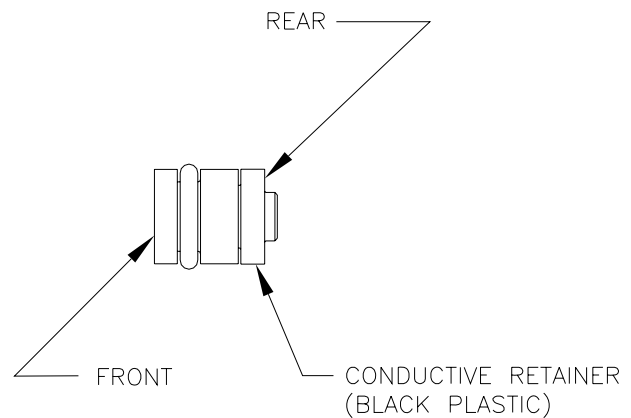

Figure 8: Cartridge Seal Assembly

7. Loosen the fluid nozzle using the special multi-purpose wrench and unscrew it by hand to remove.

Cleaning and Inspection

1. Clean the packing chamber of the barrel with a suitable solvent and a soft bristle bottle brush. **Do not submerge or soak the barrel in solvent.** If the chamber has dry paint in it and cannot be cleaned out, the barrel **MUST BE REPLACED.**

⚠ WARNING

- ▶ Soaking or submerging the barrel could allow solvents into the high voltage section of the barrel, leading to applicator failure and/or possible dangerous conditions that could result in property damage and personnel injury.

2. Examine the plastic section of the needle shaft and the packing tube for signs of carbon tracking. Also inspect the air passages and packing chamber of the barrel for signs of scratches, additional carbon tracking, or dried paint. Shine a small flashlight into the front of the barrel to highlight any damage in these areas.

⚠ CAUTION

- ▶ Barrels with dry paint, scratches, or high voltage tracking marks in the air and/or packing chamber passages **MUST BE REPLACED**. Neglecting to replace the barrel may lead to reduced applicator efficiencies and premature component failure.

3. From time to time it is desirable to test the electrical integrity of the 70430-00 Resistive Electrode. (See "Needle/Electrode Resistance Testing" in the "Maintenance" section.)

Reassembly
(Refer to Figures 9, 10, 11, and 12)

Item #	Description
9	Electrode Assembly
11	Cartridge Seal Assembly
13	2-Piece Needle Shaft Assembly

Figure 9: Front Needle Shaft Assembly

1. Prior to installing the non-adjustable cartridge seal, fill the internal bore with dielectric grease. Then place the cartridge seal, with the black plastic section rearward, onto the front of the needle shaft. Then screw it on and over the external threads of the needle shaft. Once both internal o-rings have cleared the threads, slide it onto the sealing area.

⚠ CAUTION

- ▶ Do **NOT** push the cartridge seal straight over the shaft threads. The threads will damage the internal o-rings and cause fluid leaks.

2. Screw the needle/electrode onto the front of the needle shaft and hand tighten.

Item #	Description
13	2-Piece Needle Shaft Assembly
14	Packing Tube
15	Seal Retainer
16	O-Ring
17	U-Cup
18	Spacer
20	Packing Nut
21	Trigger Adjustment Nut
82	Needle Shaft Spring Retainer

Figure 10: Rear Needle Shaft Assembly

3. Fill the inner diameter of the packing tube with dielectric grease.
4. Insert the needle shaft, rear section first, into the packing tube. Rotate the needle shaft while moving it back and forth inside the packing tube until fully inserted.
5. With your finger, wipe the excess grease from both ends of the packing tube. Using the excess grease, apply a thin film to the outer surface of the packing tube and to the external o-ring on the cartridge seal.

NOTE

► Be generous with the dielectric grease when applying it to the packing tube and needle shaft. This helps to remove air voids from this chamber. **DO NOT** apply so much grease that it creates an air lock during assembly of the applicator.

6. Apply a light film of dielectric grease to the seal retainer o-ring and install it into the external groove.
7. Insert the spring loaded u-cup seal into the seal retainer (with the concave side facing outward). Use the short end of the spacer to seat the seal.
8. While holding the rear seal retainer sub-assembly and spacer together, place these components (with the spacer rearward) onto the rear of the needle shaft and slide them over the sealing area.
9. Place the packing nut (large bore first) on the rear needle shaft section.
10. Screw the trigger adjustment nut onto the rear needle shaft section with the hexagon rearward and the spring retainer with the hexagon forward. Do not lock the hexagon nuts in place.
11. Install the needle shaft subassembly into the packing chamber from the rear of the barrel with the needle/electrode forward.

12. Push the needle shaft subassembly forward until the packing nut will engage its mating thread in the barrel and screw it into place by hand approximately 3 turns.

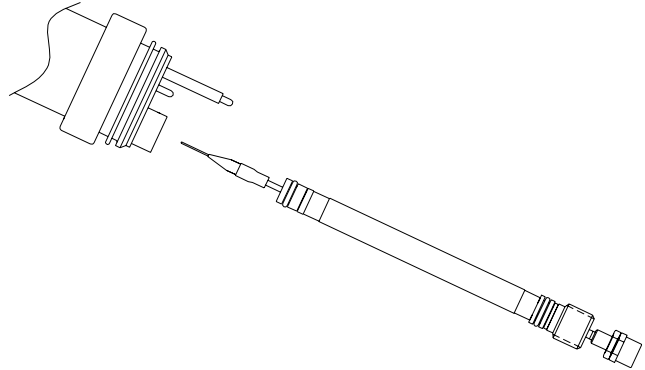

Figure 11: Needle Shaft Assembly into Barrel

13. Pull the needle shaft rearward as far as it will go.
14. Install the fluid nozzle, air cap, and retaining nut. (Refer to "Air Cap" and "Fluid Nozzle" in the "Maintenance" section.)
15. Tighten the packing nut using the spanner tool on the special multi-purpose wrench until it bottoms.

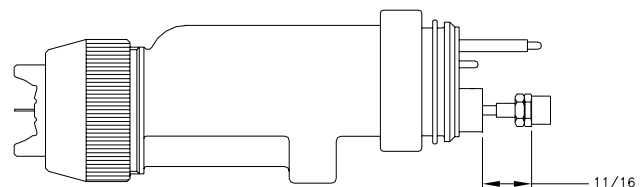

Figure 12: Trigger Adjustment Nut Dimension

16. Push the needle shaft forward until the needle/electrode seats into the fluid nozzle.
17. Adjust the trigger adjustment nut as far forward on the needle shaft as possible.
18. Adjust the needle shaft spring retainer until the rear of the hexagon is 11/16-inch from the rear surface of the barrel packing chamber (refer to Figure 12).

19. Hold the spring retainer in place and screw the front trigger adjustment nut rear-ward until contact is made. Use two 3/8-inch open-end wrenches to tighten and lock the adjustment nuts in place on the needle shaft.

CAUTION

- Do not overtighten the hexagon adjustment nuts or damage may occur to the plastic threads or the needle shaft may break. Finger tight is typically sufficient. (Maximum torque of 18-24 oz•in.)

Attaching Barrel to Handle

- If the barrel retaining nut has been removed, it will have to be reinstalled before the barrel can be attached to the handle.
- Place the retaining nut over the rear of the barrel and slide it as far forward as possible.
- Spread the retaining ring and place it onto the barrel. Starting at one end, lift the retaining ring over the captive ridge and spiral into place.

4. Place the large hole of the gasket over the needle shaft and onto the boss of the barrel packing chamber.

5. While holding the barrel with the air nozzle pointing downward, install the needle shaft spring into the spring retainer. Align the electrical connectors of the barrel with the mating holes in the hook/transformer assembly and the needle shaft spring with the spring recess in the handle. Slide the barrel into the handle cavity until it is seated against the gasket. Ensure the needle shaft spring did seat into the handle recess.

6. While holding the barrel in place, screw the retaining nut onto the handle by hand and then tighten using the special multi-purpose wrench.

NOTE

- Torque the retaining ring to 8 to 10 lb•ft or after hand tightening, torque an additional 1/6 to 1/8 turn using the special multi-purpose wrench.

Item #	Description
4	Barrel
7	Retaining Nut
8	Retaining Ring
22	Gasket
23	Handle
25	Hook / Transformer
27	Grounding Spring
82	Needle Shaft Spring Retainer
83	Compression Spring

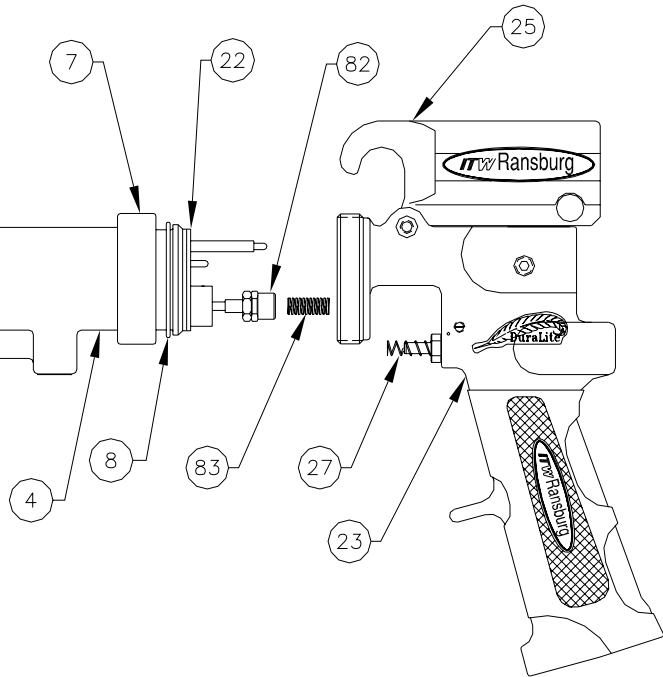

Figure 13: Barrel to Handle Assembly

7. Check the spacing between the back of the spring retainer and the handle. It should be about 1/8-inch. If not, check for one or more of the following:

- Gasket has been left out
- Loose retaining nut
- Loose fluid nozzle
- Improper adjustment of the trigger adjustment nut and spring retainer

8. Place the grounding spring over the air valve stem.

9. Pull the grounding spring back and slide the trigger into position.

10. Secure the trigger with the two shoulder screws.

NOTE

- The needle shaft travel **MUST** be checked. The air valve stem must be engaged and move back slightly before the trigger engages the trigger adjustment nut. If this does not occur then the trigger adjustment nut and/or the trigger set screw must be adjusted. The 11/16-inch dimension is only a starting place for trigger adjustment and can be altered to obtain proper triggering sequence.

NOTES

HOOK / TRANSFORMER ASSEMBLY

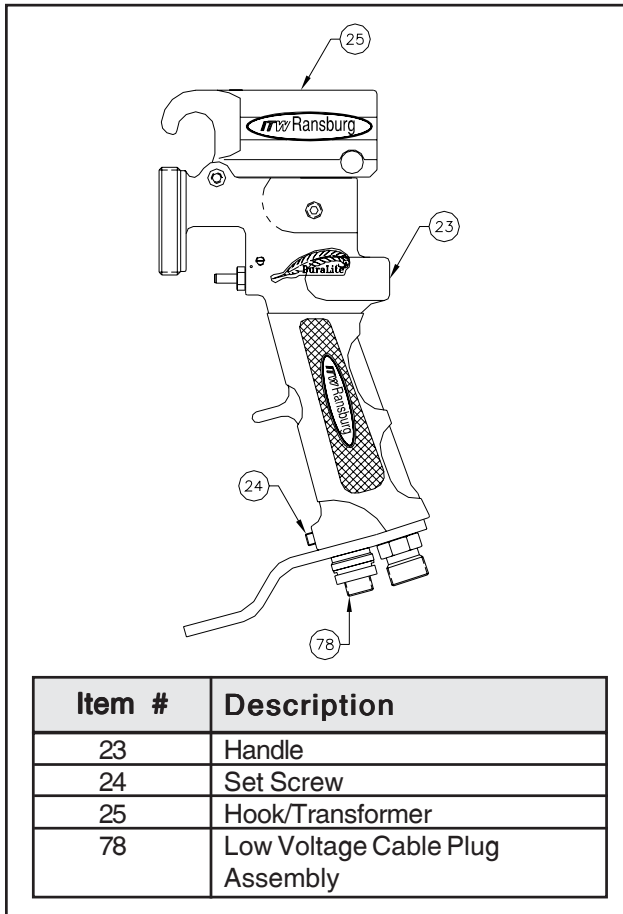

Figure 14: Hook/Transformer Removal

Removal

1. The following procedures must be performed prior to removing the hook/transformer assembly:

- Barrel Removal from Applicator
- Low Voltage Cable Removal
- Fluid Hose Removal and Fluid Tube Removal (for Solvent Base Applicators)
- Low Voltage Cable Plug Assembly Removal

2. Remove the gasket from the handle if it did not come out with the barrel.

3. Slide the hook/transformer forward and out of the handle channel.

Testing and Repair

NOTE

► The hook/transformer can be tested using the Transformer Output Tester and following the guidelines of its instruction manual. If the transformer output tester is not available, the following procedure can be used to test the hook/transformer.

1. Prior to testing the hook/transformer, the following test procedures must be conducted.

- Low Voltage Cable Test
- Low Voltage Cable Plug Assembly Test

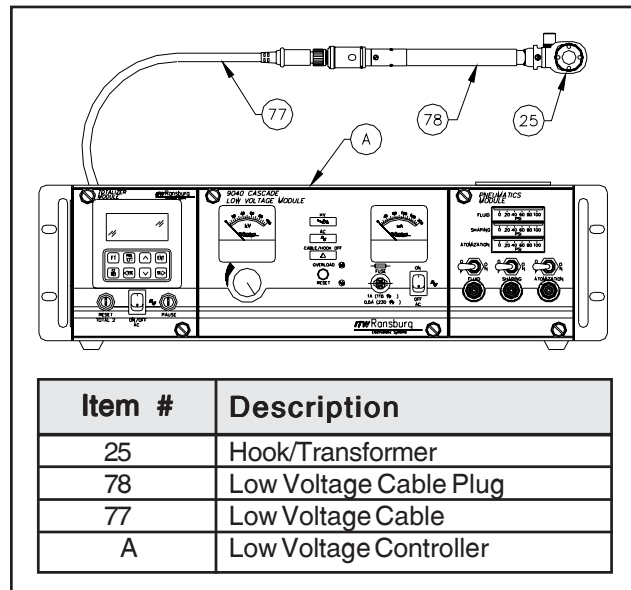

Figure 15: Hook/Transformer Test Setup Diagram

2. Connect the low voltage cable to a control unit and a cable plug assembly (refer to Figure 15).

3. Connect the low voltage cable and the plug assembly to the hook/transformer. This can be done without the handle on a workbench or with the hook/transformer, low voltage cable, and plug assembly installed into a handle. **DO NOT** perform this test with the barrel attached to the hook/transformer.
4. On the control unit, turn the high voltage adjustment knob fully counter-clockwise.
5. Make sure that the on/off switch of the hook/transformer is in the "ON" position, if the unit has this option (refer to Figure 16).
6. Turn the control unit on and adjust the voltage knob clockwise to increase the voltage to the hook/transformer.
7. Watch the red lens at the rear of the hook/transformer. As the voltage is increased, the LED behind the lens will increase in intensity. Once the voltage control knob is turned fully clockwise, the LED should be at it's highest intensity.

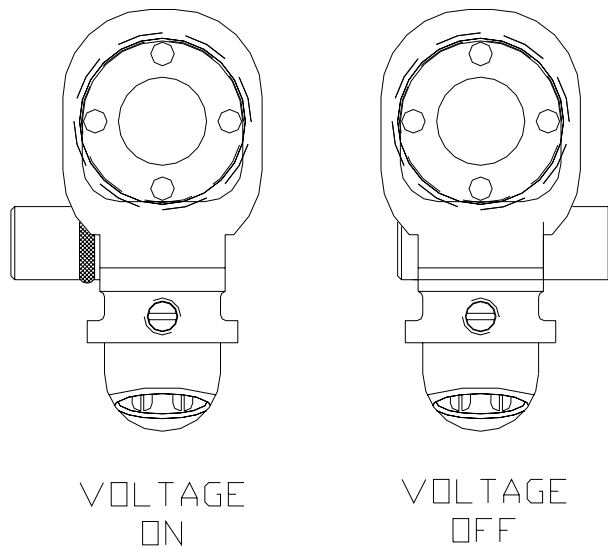

Figure 16: Hook/Transformers Switch Position

8. If the LED does not light, check the position of the on/off switch. It must be in the ON position. If the switch is in the correct position, replace this unit (refer to "Hook Transformer On/Off Switch Replacement") and retest.
9. If the LED will not light after replacing the switch, the hook/transformer is bad and must be replaced.

Replace LED Lens

1. If the lens that covers the LED of the hook/transformer is cracked or broken, the lens should be replaced.
2. With a spanner wrench, unscrew the lens from the hook/transformer.
3. Install a new replacement lens using a spanner wrench.

Reinstall

1. Apply dielectric grease to the rails of the hook/transformer and the associated channel of the handle.
2. Slide the rails of the hook/transformer into the channels of the handle, red lens side first. Push the hook/transformer rearward until seated into handle chamber.
3. Check the alignment of the hook/transformer face to that of the handle face (they must be flush).
4. If they are not flush, remove the hook/transformer from the handle and adjust the set screw on the back of the hook/transformer.
 - a.) If the hook/transformer face protrudes beyond the handle face, turn the set screw clockwise.
 - b.) If the hook/transformer face is recessed, turn the set screw counter-clockwise.

HOOK / TRANSFORMER ON/OFF SWITCH REPLACEMENT

Removal

1. With the hook transformer removed from the handle, locate a small set screw just under the on/off switch.
2. With a small screw driver, unscrew the set screw from the hook transformer until the on/off switch can be pushed out.

Cleaning and Inspection

There is no reason to clean the on/off switch. The switch is not repairable and must be replaced.

Reinstall

1. Apply a light coating of dielectric grease to the on/off switch.
2. With the hook transformer setting with the set screw facing upward and the LED lens facing toward you, slide the on/off switch into the hook transformer so that the slot in the switch is on the left side of the hook transformer and in line with the set screw.
3. Hold the on/off switch and screw the set screw into the hook transformer until it just contacts the switch body.
4. Check the action of the switch by sliding it back and forth in the hook transformer. The switch should slide back and forth with light resistance.
 - a.) If the on/off switch is hard to move, loosen the set screw.
 - b.) If it moves when the hook transformer is tilted from side to side, tighten the set screw.

5. Retest the hook transformer prior to reinstalling into the handle. (Refer to "Hook/Transformer Assembly - Testing and Repair" in the "Maintenance" section.)

HANDLE

Removal

1. Prior to working on the applicator handle, the following procedures should be completed.

- Removal from Service
- Removal Fluid Tube and Fluid Hose
- Removal Air Hose
- Removal Low Voltage Cable
- Removal Low Voltage Cable Plug Assembly
- Removal Trigger
- Removal Barrel
- Removal Fluid Tube Bracket
- Removal Hook/Transformer
- Removal Fan Air Screw
- Removal Air Valve
- Removal Trigger Stop

2. The handle can now be completely disassembled of all components. There are five (5) pipe plugs that were installed at the factory and should not be removed.

Cleaning and Inspection

1. The handle can be cleaned and/or soaked in a suitable solvent to remove all paint from the outer surfaces and the interior passages.
2. The handle is very durable and usually not damaged during normal operations. Examine the handle for cracks, chips, and/or broken parts. If any are noted the handle must be replaced.

Assembly

1. To get the applicator ready to be placed back into service, perform the following procedures.

- Install Trigger Stop
- Install Air Valve
- Install Fan Air Screw
- Install Hook/Transformer
- Install Barrel to Handle
- Install Fluid Tube Bracket
- Install Trigger
- Install Low Voltage Cable Plug Assembly
- Install Low Voltage Cable
- Install Air Hose
- Install Fluid Tube and Fluid Hose
- Placing Applicator Back in Service

FAN AIR VALVE

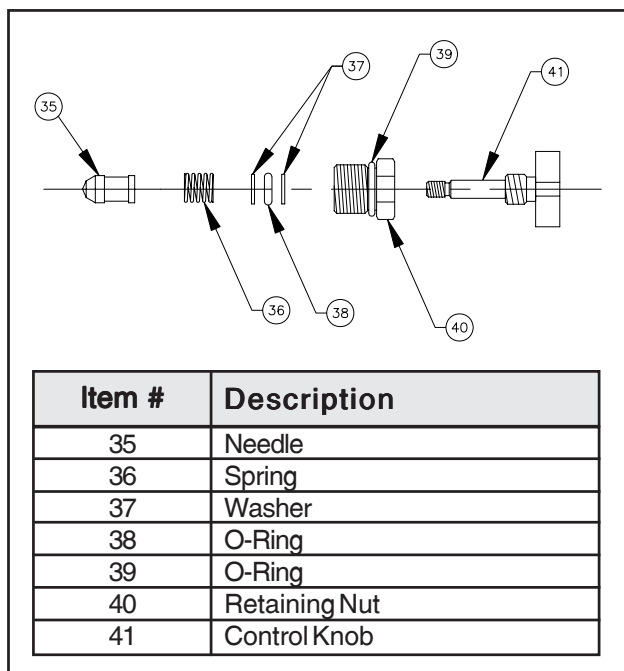

Figure 17: Fan Air Screw

Removal

(Refer to Figure 17)

1. Turn control knob to the open position (screwed fully out, counter-clockwise).
2. With a 9/16-inch wrench, unscrew the retaining nut and remove the entire valve assembly.

Disassembly

1. Turn the control knob clockwise to the closed position or until it bottoms on the retaining nut.
2. Secure the control knob in a vise (do not overtighten, it could break the control knob) with the needle pointing upward.
3. With a 1/4-inch wrench on the wrench flats of the needle, unscrew the needle and remove it from the control knob stem.

CAUTION

► With the control knob turned fully into the retaining nut the tension on the spring is relieved. If it is not, the needle could be projected from the control knob stem and cause personal injury.

4. Remove the spring from the control knob stem.
5. Unscrew the control knob and pull it out of the retaining nut.
6. With a small rod (1/4-inch diameter), push the two washers and Teflon o-ring out of the retaining nut.

Cleaning and Inspection

1. Discard both o-rings. They should be replaced with new ones.
2. Clean the parts in a suitable solvent.
3. Check all components for damage and also check the needle for wear. Replace any damaged or worn parts.

Assembly

1. Apply a light coating of dielectric grease to a new o-ring and slide it over the threads of the retaining nut until it sets into the thread relief.
2. Apply a light coating of dielectric grease to the control knob threads and screw it into the retaining nut to the closed position or until it bottoms.
3. Place the first washer, a new Teflon o-ring, and then a second washer onto the control knob stem. Slide the components into the retaining nut bore.
4. Place the spring over the control knob stem and into the retaining nut bore.
5. Secure the control knob in a vise with the control knob stem pointing upwards. Apply a small amount of medium strength thread locker to the threads of the control knob stem.
6. Screw the needle onto the control knob stem and with a 1/4-inch wrench, tighten the needle.

Reinstall

1. Turn the control knob to the open position (screwed fully out, counter-clockwise).
2. Screw the retaining nut into the handle by hand. Using a 9/16-inch open-end wrench, secure the retaining nut into the handle.
3. Screw the control knob to it's closed position.

AIR VALVE

(Refer to Figure 18)

Removal

1. Remove the trigger and ground spring from the handle (refer to "Trigger" in the "Maintenance" section).
2. With a standard blade screwdriver, remove the air valve cap from the back of the handle.
3. Remove the compression spring from the back of the air valve rod assembly.
4. From the front of the handle, push the air valve rod assembly rearward until it can be removed by hand from the back of the handle. **Do not use any tools to grip the air valve. This can damage its sealing surface.**

NOTE

- ▶ A rod (1/8-inch diameter or smaller) can be used to push the assembly out the back of the handle until it can be gripped with the fingers.

5. With a 3/8-inch wrench, completely remove the retaining nut with the internal u-cup seal.

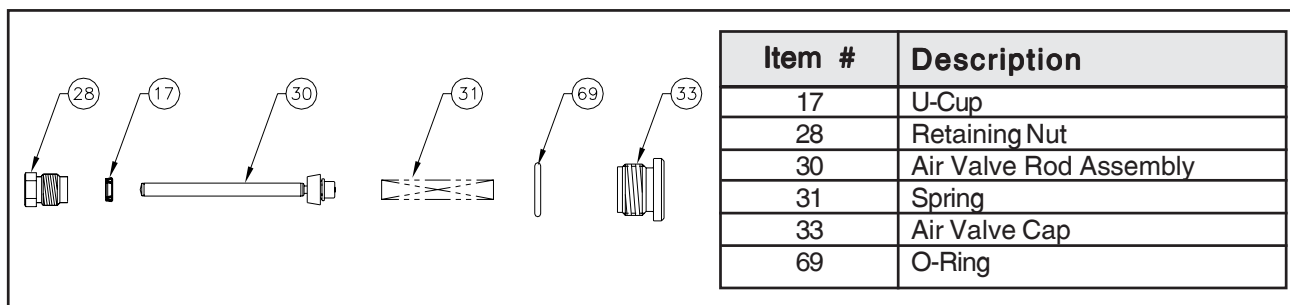

Figure 18: Air Valve

Cleaning and Inspection

1. Remove the o-ring from the air valve cap.
2. Clean all components with a suitable solvent.
3. Inspect the air valve rod assembly for wear and/or damage. If any wear is found on the air valve rod assembly, it and the u-cup seal must be replaced.

CAUTION
<p>► The seal internal to the air valve retaining nut cannot be reused once it has been removed from its holder.</p>

4. Inspect all other parts for damage. Replace any damaged components.
5. Inspect the brass seat in the handle for damage or wear. If damaged or worn, the handle must be replaced. (Refer to "Handle" in the "Maintenance" section.)

Reinstall

1. Install the new spring loaded u-cup seal, spring side (cup portion) outward, into the air valve retaining nut. Apply a coating of Teflon thread sealant to the threads of the retaining nut and screw it fully into the handle. Use 3/8 open-end wrench to tighten.
2. Apply a thin film of lubricant around the shaft just behind the brass tip of the air valve rod assembly.
3. Install the air valve, rod end first, into the air valve chamber from the back on the left side of the handle and push it through the retaining nut.
4. Install the compression spring onto the back of the air valve.
5. Apply a thin film of lubricant on the o-ring and install it into the thread relief of the air valve cap.

6. Install the assembled air valve cap containing the o-ring seal into the handle using a standard blade screwdriver.

TRIGGER

Removal (Refer to Figure 19)

NOTE

- The applicator trigger can be replaced either with the applicator on-line or removed from service. If the following procedure is to be done online, make sure that all fluid and air sources are shut off to the applicator and the pressure in the lines is relieved. Most of all make sure that the power supply is turned off.

1. Remove the two (2) shoulder screws that attach the trigger to the applicator.
2. Hold the grounding spring in position and remove the trigger from the applicator assembly.
3. Remove the grounding spring from the rod portion of the air valve and set it aside for safe keeping.

Cleaning and Inspection

1. Clean the trigger with a suitable solvent and dry.
2. Inspect the trigger for damage or wear and replace if necessary.

Reinstall

1. Install the ground spring onto the rod portion of the air valve and hold it in place.
2. Slide the trigger onto the handle and align the holes with the threaded holes in the handle.

3. Insert the shoulder screws through the holes of the trigger and screw them into the handle by hand.

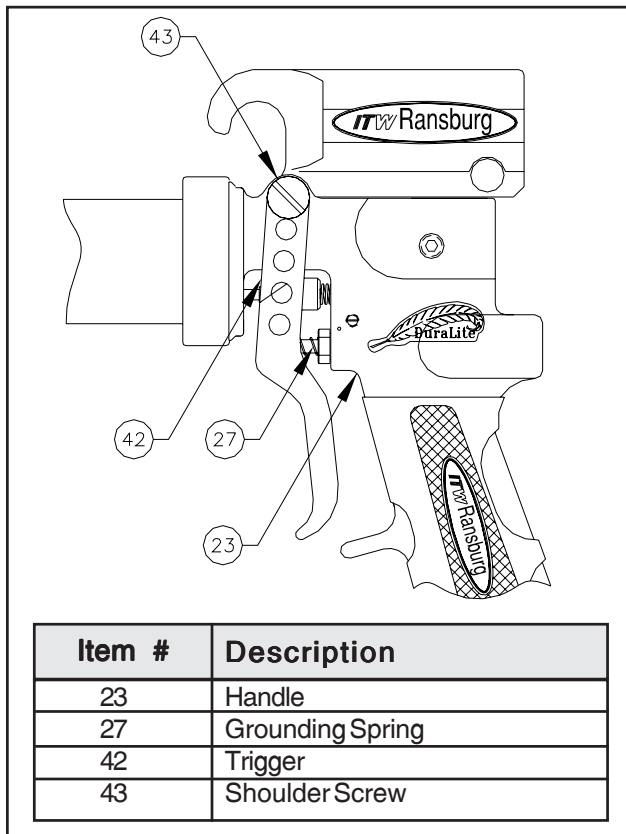

Figure 19: Trigger Removal

4. Secure the shoulder screws to the handle using a flat blade screwdriver.

NEEDLE SHAFT RETURN SPRING REPLACEMENT

Removal

1. Remove the trigger and ground spring from the applicator (refer to "Trigger" in the "Maintenance" section).
2. Loosen the barrel retaining nut and slide it forward on the barrel.
3. Pull the barrel forward until there is enough clearance between the needle shaft spring retainer and the handle to remove the spring.

Cleaning and Inspection

1. Clean all the components in a suitable solvent and dry.
2. Check all components for wear, fatigue, or damage and replace as required.

Reinstall

1. Install a new spring into the needle shaft spring retainer.
2. Slide the barrel back into the handle cavity until it seats against the barrel gasket.
3. Check the spring to ensure it has seated into the handle recess and tighten the barrel retaining nut.
4. Reinstall the trigger and ground spring (refer to "Trigger" in the "Maintenance" section).

LOW VOLTAGE CABLE PLUG ASSEMBLY REPLACEMENT

(Refer to Figure 20)

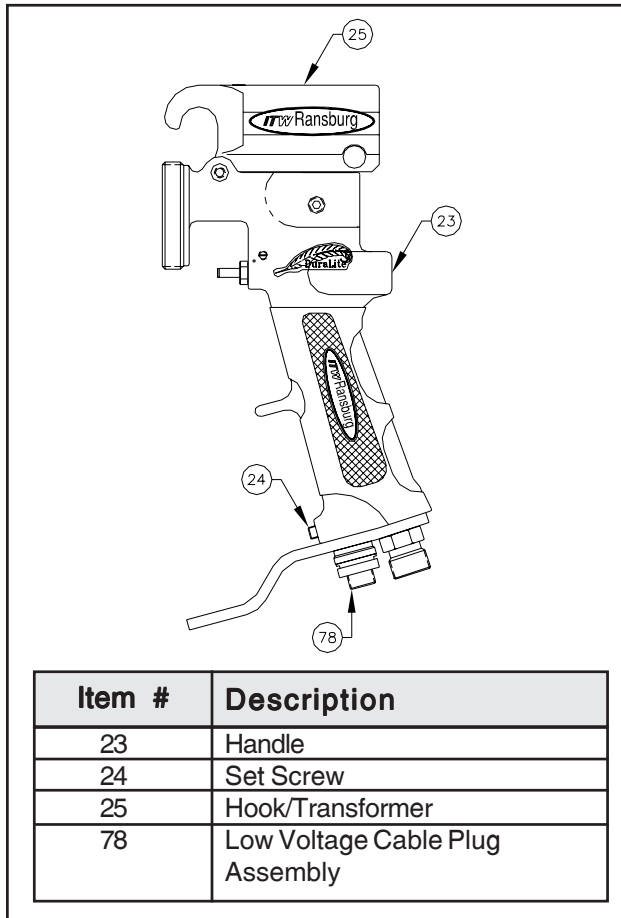

Figure 20: Low Voltage Cable Plug Removal

Removal

1. Remove the applicator from service (refer to "To Remove the Applicator from the Work Site" in the "Maintenance" section).
2. On solvent base applicators it might be necessary to remove the fluid tube and fitting before removing the low voltage cable plug assembly. (Refer to "Fluid Tube" in the "Maintenance" section.)

3. Use a 3/32-inch hexagon Allen wrench to loosen (DO NOT remove) the set screw that retains the low voltage cable plug assembly to the handle. The set screw is located toward the bottom of the handle on the front side (see Figure 20).

4. Hold the bottom of the plug assembly and pull it straight out of the handle.

CAUTION

► Trying to twist or unscrew the low voltage cable plug assembly from the handle will damage the low voltage plug assembly and the hook/transformer. If this occurs, both components have to be replaced.

Cleaning and Inspection

1. The low voltage cable plug assembly should not be cleaned or soaked in any solvents. If the assembly is contaminated, it must be replaced.

2. Examine the low voltage cable plug assembly for damage to the housing, broken wires, and/or broken solder joints. If any are found the assembly must be replaced.

3. Examine the five (5) o-rings of the low voltage cable plug assembly and replace any that are damaged.

4. If the old low voltage cable plug assembly is to be reinstalled into the gun, it should be tested first. (Refer to Low Voltage Control Unit Test Assembly manual.)

Reinstall

1. Apply a light coating of dielectric grease to the three (3) o-rings and insert the low voltage cable plug assembly into the handle. (DO NOT push the assembly fully into the handle.)

2. Rotate the plug assembly until the slot in the aluminum housing is aligned with the set screw in the handle.

3. Push the low voltage cable plug assembly into the handle until it seats into the hook/transformer assembly.
4. Tighten the set screw until it seats into the alignment slot of the low voltage cable plug assembly.

LOW VOLTAGE CABLE REPLACEMENT

WARNING

- ▶ Prior to working and/or performing maintenance on any part of the applicator assembly, make sure that the control unit, AVIATOR, or MGS System are turned off (locked and/or tagged out). Also make sure that all residual voltage is drained from the system by grounding the needle/electrode.

Removal

1. Using a wrench, unscrew the low voltage cable assembly from the low voltage cable plug assembly in the handle.
2. Remove the low voltage cable assembly from the plug assembly by pulling straight out.
3. Unscrew the low voltage cable assembly from the control unit.
4. Remove the low voltage cable assembly from the fluid and air hose bundle.

NOTE

- ▶ The low voltage cable assembly is not repairable due to it's construction. The cable assembly must be replaced.

Cleaning and Inspection

1. If prior testing has shown that the low voltage cable assembly is bad, the cable assembly must be replaced.
2. If the low voltage cable assembly has not been tested, it should be tested. (Refer to "Low Voltage Control Unit Test Assembly" manual.)
3. The low voltage cable assembly can be wiped with a suitable solvent. DO NOT soak or submerge the cable assembly in solvent.
4. Check the full length of cable for wear or breaks in the cable sheathe. If any are found, the cable assembly should be replaced.

CAUTION

- ▶ Do NOT overtighten the low voltage cable connection to the applicator as damage to plastic parts may occur.

Assembly

1. Connect the low voltage cable assembly to the low voltage cable plug assembly of the handle.
2. Route the low voltage cable assembly back to the low voltage control unit and attach the cable assembly into the air hose/fluid hose bundle.
3. Connect the low voltage cable assembly to the low voltage control unit.

FLUID TUBE (Refer to Figure 21)

Removal

1. Remove the applicator from service. (Refer to "To Remove the Applicator from the Work Site" in the "Maintenance" section.)
2. At the fluid tube bracket, unscrew the plastic nut from the fitting using a 3/4-inch open end wrench and slide it up the fluid tube.
3. Unscrew the fluid tube connector nut and slide it down the fluid tube.
4. Pull the fluid tube out of the fitting at the fluid tube bracket.

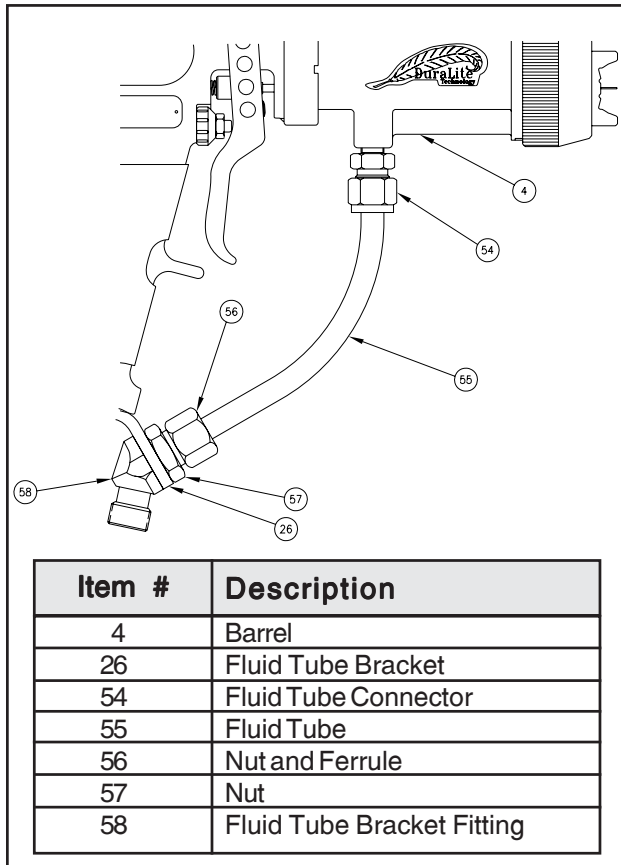

Figure 21: Fluid Tube Components

5. If the fluid tube will not pull out of the fitting, it might be necessary to remove the fluid tube bracket from the applicator. (Refer to "Fluid Tube Bracket" in the "Maintenance" section.)

6. Remove the fluid tube and ferrules from the connector body in the barrel.

Cleaning and Inspection

1. Clean the fluid tube, associated fittings, and ferrules in a suitable solvent.

NOTE

► The inside diameter of the fluid tube should only be cleaned by flushing solvent through it while in service. No attempt should be made to clean the inside diameter of the fluid tube once it is removed from the applicator. If there is paint residue in the bore it should be replaced. Also, if the outer surface is contaminated or damaged it should be replaced.

2. Inspect the fluid tube for paint contamination and/or damage. If any is found it should be replaced.

CAUTION

► The accumulation of paint on the outer surface of the fluid tube can lead to reduced applicator efficiency and/or electrical damage.

Reinstall

1. At one end of the fluid tube, place the nut and ferrule that will attach to the fluid tube bracket fitting.

2. At the opposite end, install the fluid tube connector nut and ferrules. Place this end of the fluid tube into the fluid tube connector body and push it into the bore until seated.

3. Slide the nut and ferrules onto the fluid tube connector and tighten using an 11/16-inch open end wrench.
4. Flex the fluid tube slightly until the other end fits into the fitting on the fluid tube bracket. If the fluid tube will not flex enough, loosen the fitting from the bracket.

NOTE

- ▶ DO NOT overflex the fluid tube into the fitting. This will kink the tube and it will have to be replaced.

5. Slide the nut and ferrule into position to engage the fitting and hand tighten.
6. With a 3/4-inch open end wrench, secure the nut to the fitting.

FLUID HOSE

Removal

1. With a 3/4-inch open end wrench, unscrew the fluid hose nut from the fluid tube bracket fitting and remove the fluid hose.
2. Remove the fluid hose from the fluid supply.

Cleaning and Inspection

1. The outer surface of the fluid hose can be wiped with a suitable solvent.

NOTE

- ▶ If the fluid hose will not flow solvent when the applicator is removed from service, it is plugged and must be replaced. Fluid hoses should be replaced periodically, depending on the type of materials being sprayed.

2. Check the hose outer surface for wear or cuts and replace as necessary.

Reinstall

1. To reinstall an existing or new fluid hose refer to "Fluid Hose" in the "Maintenance" section.

AIR LINE

Removal

1. With a wrench, hold the air fitting in place and loosen the air hose nut using a second wrench. Completely unscrew the nut and remove the air hose assembly.
2. Disconnect the air hose from the flow switch port at the low voltage control unit.
3. Remove the air hose assembly from the fluid hose and low voltage cable bundle.

Cleaning and Inspection

1. The outer surface of the air hose assembly can be wiped with a suitable solvent. Do not submerge or soak the air hose in solvent.

CAUTION

- ▶ Soaking or submerging the air hose assembly in solvent can lead to premature failure of the hose assembly.

2. Inspect the air hose for physical damage to the hose and fittings. If any is found, replace the hose assembly.

Reinstall

1. Connect the air hose to the air fitting of the applicator assembly. With a wrench, hold the air fitting in place and tighten the air hose nut using a second wrench.
2. Reroute the air hose back into the fluid hose and low voltage cable bundle.
3. Connect the air hose to the flow switch port marked out on the low voltage control unit.

FLUID TUBE BRACKET

Removal

1. Remove the fluid tube. (Refer to "Fluid Tube" in the "Maintenance" section.)
2. Remove the low voltage cable from the plug assembly.
3. Remove the air hose from the air fitting.
4. With an 11/16-inch open end wrench, unscrew the air fitting from the handle.
5. The fluid tube bracket should come off with the air fitting and o-ring attached.
6. Remove the o-ring from the air fitting stem and pull the air fitting through the fluid tube bracket.

Cleaning and Inspection

1. Clean the fluid tube bracket in a suitable solvent.
2. Damage to the fluid tube bracket is uncommon. Set it aside for future service.

Reinstall

1. Insert the air fitting from the bottom of the fluid tube bracket. Lubricate lightly a new o-ring with dielectric and slide it over the air fitting.
2. Position the fluid tube bracket over the low voltage cable plug assembly and screw the air fitting into the handle. Tighten with a wrench, however do not over-tighten the fitting causing damage to the handle.
3. Reconnect the low voltage cable to the plug assembly.
4. Reconnect the fluid tube to the fluid tube bracket fitting. (Refer to "Fluid Tube" in the "Maintenance" section.)

TRIGGER ADJUSTMENT

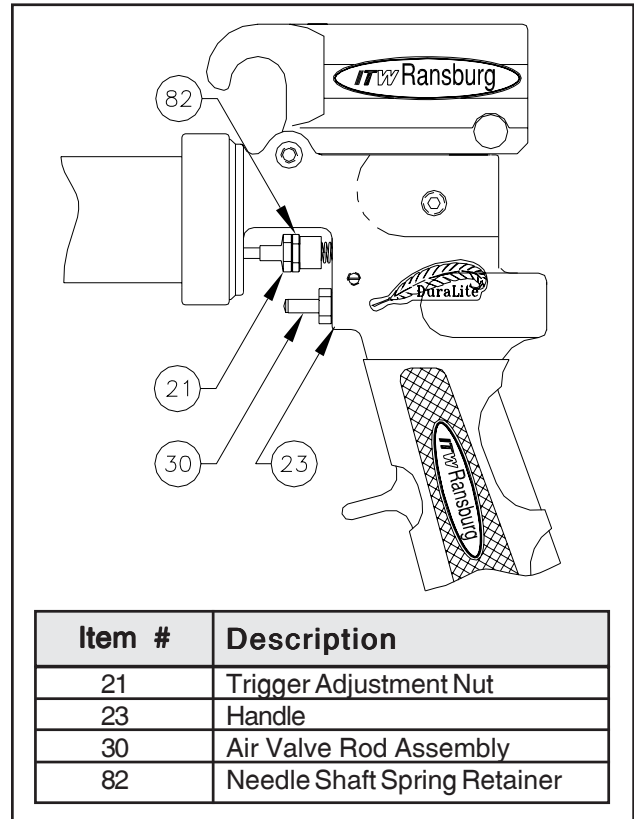

Figure 22: Trigger Adjustment

NOTE

- The following procedure is to set the sequence of operation for air and fluid as the trigger is actuated. It is very important that atomizing air be introduced before the fluid. If fluid is energized prior to the air, the applicator will spit large paint particles onto the part being coated.

1. Actuate the trigger slowly, watching the sequence of mechanical operation. The trigger set screw should engage the air valve before the strike plate of the trigger contacts the front adjustment nut on the needle shaft assembly.

2. If the sequence of operation is out of order, ensure that the distance between the back surface of the barrel packing chamber to the back of the hexagon of the needle shaft spring retainer is 11/16-inch (refer to Figure 12).

3. Normally if this distance is correct, the mechanical sequence will function properly. If not, check the assembly for problems such as a missing gasket, loose fluid nozzle, loose needle electrode, or damage to any of these components.

4. To readjust the 11/16-inch distance, the trigger and ground spring must be removed. Then the hexagon nuts may be loosened using two (2) 3/8-inch open-end wrenches.

5. To delay fluid actuation, increase the 11/16-inch distance or to quicken the actuation of fluid decrease this distance. Be sure not to over adjust in either direction. A distance to great will not allow full needle travel or a distance to short may not allow adequate spring force on the needle valve.

6. After establishing the proper mechanical sequence of air then fluid actuation, reinstall the ground spring and trigger.

7. Another adjustment is turning the trigger set screw clockwise, reducing the distance required to engage the air valve and counter-clockwise to increase the distance. Be sure not to over adjust in either direction.

FAN AIR ADJUSTMENT

The fan air screw adjustments should be made during normal spray operating conditions. The adjustment of the screw is dependent on the material being sprayed, the desired spray pattern, and the spray technology type. Turning the fan air screw clockwise will close the pattern and turning it counter-clockwise will open it up. For additional information on adjusting the spray pattern, refer to REA Applicator Spray Techniques manual.

FLUID DELIVERY ADJUSTMENT

Fluid delivery to the spray applicator should be made external to it. Some fluid adjustments can be done on the applicator by adjusting the trigger stop screw. When the stop is adjusted fully back (clockwise), the spray applicator should be at maximum fluid delivery. By turning the trigger stop forward (counter-clockwise), the fluid delivery can be reduced.

ATOMIZING AIR ADJUSTMENT

The atomizing air supplied to the spray applicator can only be adjusted external to the applicator. There is no means of adjusting the atomizing air pressure at the spray applicator.

TROUBLESHOOTING GUIDE

General Problem	Possible Cause	Solution
DEFECTIVE SPRAY PATTERN		
Pattern Will Not Shape	<ol style="list-style-type: none"> 1. Clogged or faulty fan air valve 2. Air passages in applicator or air line clogged 3. Worn, faulty, or clogged air cap 	<ol style="list-style-type: none"> 1. Clean, repair, or replace. 2. Blow out, clean, or replace. 3. Clean or replace.
Pattern Heavy at One End	<ol style="list-style-type: none"> 1. Clogged or faulty air cap 2. Clogged or faulty fluid nozzle 	<ol style="list-style-type: none"> 1. Clean or replace. 2. Clean or replace.
Extremely Heavy Spitting or Severely Deformed Pattern	<ol style="list-style-type: none"> 1. Wrong air cap/fluid nozzle combination 2. Faulty air cap 	<ol style="list-style-type: none"> 1. Ensure proper fluid nozzle/air nozzle pressure reducer combinations (see "Air Cap/Fluid Nozzle Selection Chart" in the "Installation" section.). 2. Replace.
No Control of Round Spray Pattern While in Air Spray Mode	<ol style="list-style-type: none"> 1. Wrong fan control valve installed 	<ol style="list-style-type: none"> 1. Replace with proper fan control valve. See "Parts Identification" section for proper assembly number.
INADEQUATE DELIVERY		
Air	<ol style="list-style-type: none"> 1. Air passages in applicator or air line clogged 2. Inadequate air source 3. Paint in air passage 	<ol style="list-style-type: none"> 1. Blow out. 2. Increase. 3. Clean and blow out.
Fluid	<ol style="list-style-type: none"> 1. Clogged or faulty fluid nozzle 2. Clogged passages in applicator fluid tube or fluid line 3. Insufficient needle/electrode travel 4. Low fluid supply pressure 5. Clogged fluid filter 6. Clogged or obstructed valve or fluid regulator 	<ol style="list-style-type: none"> 1. Flush or replace. 2. Flush. 3. Adjust (see "Trigger Adjustment" in the "Maintenance" section). 4. Increase. 5. Clean or replace. 6. Clean as required or replace.

General Problem	Possible Cause	Solution
LEAKAGE		
Air	1. Defective valve seat or valve spring	1. Clean and lubricate or replace.
Air (At plugged machine holes in body or at air valve cap at rear of body)	1. Loose or defective plugs or cap	1. Tighten or replace Teflon tape.
Fluid (At rear of barrel)	1. Cartridge seal assembly and/or needle/electrode shaft defective	1. See "Barrel Assembly" in the "Maintenance" section.
Fluid (Slight leak at nozzle when trigger is released)	1. Nozzle not secure 2. Air valve closing before fluid valve	1. Tighten. 2. Adjust needle shaft/electrode travel.
Fluid (Constant at nozzle)	1. Worn or damaged fluid nozzle 2. Worn or damaged needle/electrode 3. Loose fluid nozzle 4. Needle/electrode does not seat when trigger is released	1. Replace fluid nozzle. 2. Replace. 3. Tighten. 4. Adjust (see "Trigger Adjustment" in the "Maintenance" section).
ELECTRICAL		
Wrap Back	1. Improper target ground 2. Improper spray technique 3. Improper booth exhaust 4. Excessive atomizing air 5. Excessive target distance	1. Trace and correct (1 megohm maximum ground to target resistance). 2. See ITW Ransburg "REA Applicator Spray Techniques" manual. 3. Trace and correct. 4. Reduce pressure. 5. Decrease distance between applicator and target.
Improper or No High Voltage	1. Faulty low voltage cable connections 2. Faulty transformer/hook assembly 3. Improper or no ground at control unit 4. Faulty barrel/cascade assembly 5. Faulty low voltage cable 6. Faulty control unit	1. Check and secure at the applicator and at the control unit. 2. Replace. 3. Trace and correct (1 megohm maximum ground to target resistance). 4. Replace. 5. Replace. 6. See the control unit manual.

TROUBLESHOOTING GUIDE (Cont.)

General Problem	Possible Cause	Solution
ELECTRICAL (Continued)		
Improper or No High Voltage (Continued)	7. Check fuses 8. Is the power turned on? 9. Is the atomizing air turned on? 10. Is the applicator triggered? 11. Is the hook transformer on? 12. Is the paint too conductive?	7. Replace fuse. 8. Check power supply. 9. Check air regulator. 10. Check applicator trigger. 11. Check hook transformer switch. 12. Check conductivity of paint.
Isolation System Grounded Out	1. Failed fluid hose 2. Isolation stand or charged equipment too close to ground	1. Replace fluid hose. 2. Provide adequate ground distance.

NOTES

PARTS IDENTIFICATION

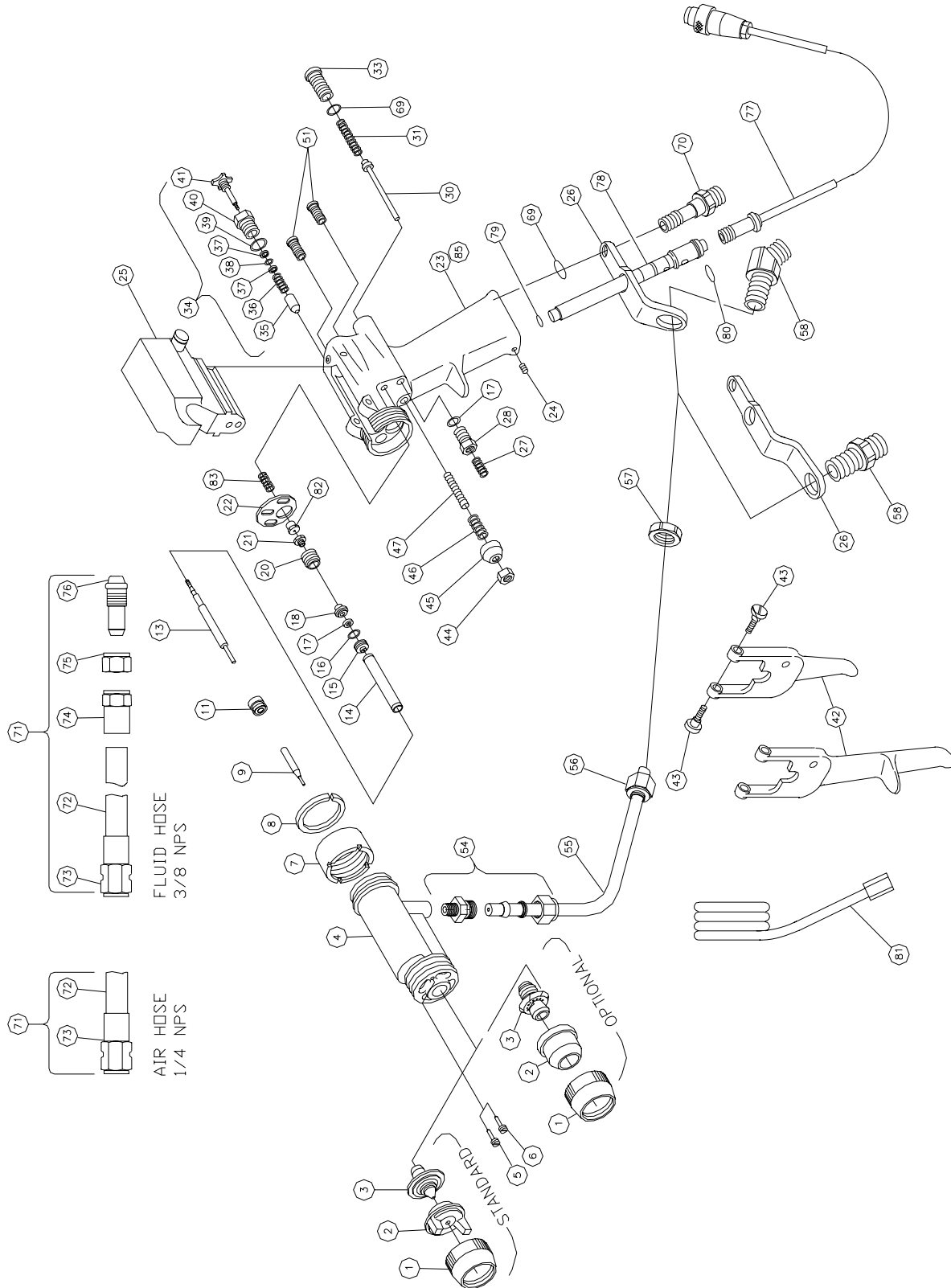
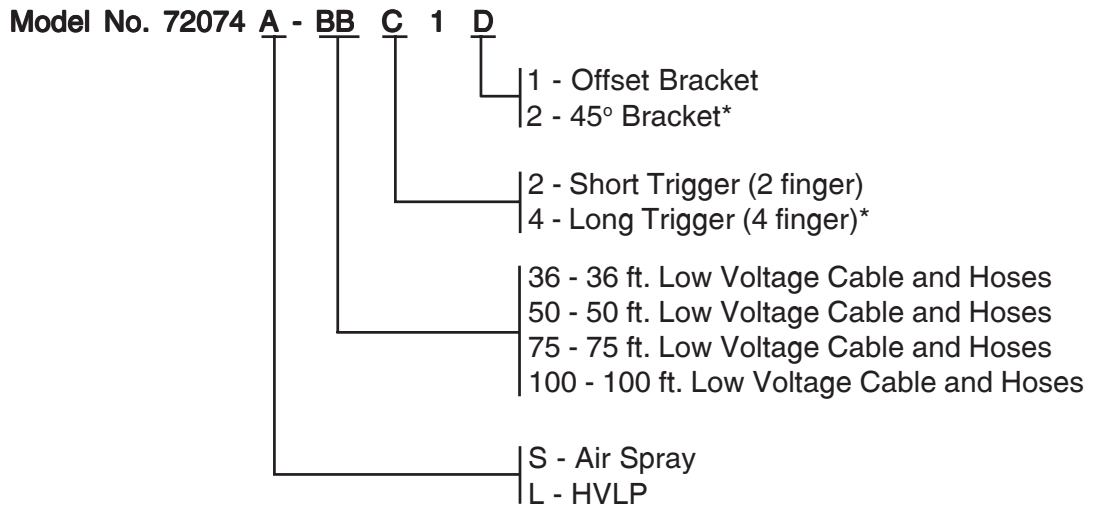

Figure 23: 72074 (Standard) and 75980 (AVIATOR/MGS)

72074 SOLVENT BASE REA-70 STANDARD MODEL IDENTIFICATION

The REA-70 and REA-70L applicators are available with a short or a long trigger, and with various low voltage cable and fluid, and air hose lengths as follows:



* **Note:** The long trigger cannot be used with the 45° bracket.

75980 SOLVENT BASE REA-70 AVIATOR/MGS MODEL IDENTIFICATION

The REA-70 and REA-70L applicators are available with a short or a long trigger, and with various low voltage cable and fluid, and air hose lengths as follows:

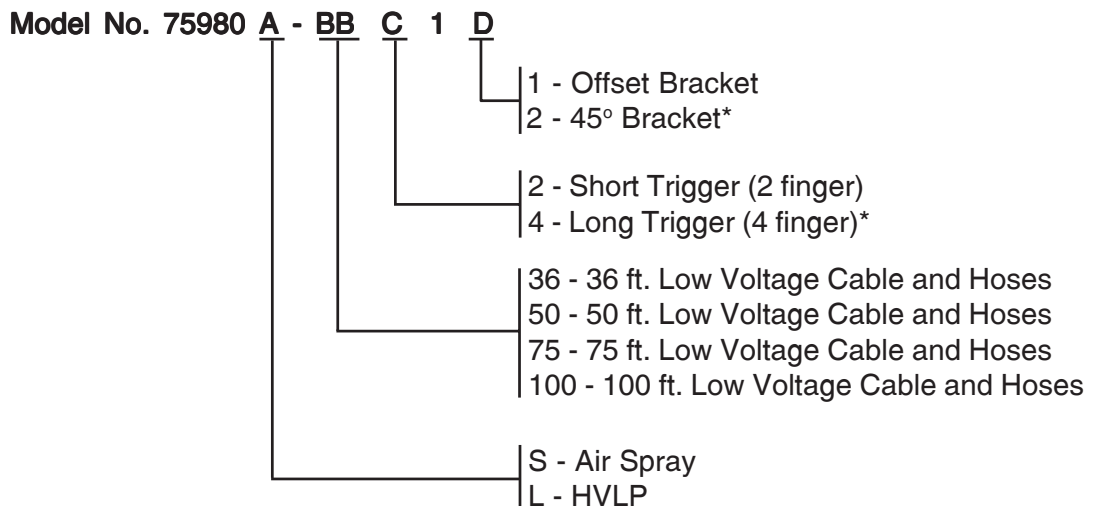

* **Note:** The long trigger cannot be used with the 45° bracket.

REA-70 & 70L SPRAY APPLICATORS (72074 & 75980) - PARTS LIST (Figure 23)		
Item #	Description	Part #
	REA-70 Delta Applicator (Air Spray) Complete Assembly (Solvent Base Systems Only):	
	For Standard 9040	72074S-BBC1D
	For AVIATOR / MGS	75980S-BBC1D
	REA-70L Delta Applicator (HVLP) Complete Assembly (Solvent Base Systems Only):	
	For Standard 9040	72074L-BBC1D
	For AVIATOR / MGS	75980L-BBC1D
1 ²	Retaining Ring:	
	Swirl	4903-00
	HVLP, Air Spray, and Round	73569-00
2 ²	Air Cap:	
	Flat Pattern, HVLP	75601-00
	Flat Pattern, Air Spray	4904-xx*
	Round Pattern, Swirl	70899-00
	Round Pattern, Round	LREA0002-00
3 ²	Fluid Nozzle:	
	Flat Pattern, HVLP	75600-01
	Flat Pattern, Air Spray	4907-XX*
	Round Pattern, Swirl	70898-00
	Round Pattern, Round	LREA0003-00
4	Barrel, REA-70	75036-00
5	Reducer, Pressure, Air Spray, Black	74963-02
6	Reducer, Pressure, HVLP, White	74963-03
7	Nut, Retainer, Barrel	75323-00
8	Ring, Retaining, Barrel	75326-00
9	Electrode Assembly	70430-00
10	----	----
11 ³	Seal Assembly, Cartridge, Non-Adjustable, REA	78626-00
12	----	----
13 ³	Shaft Assembly, 2-Piece Needle, REA	78627-05
14 ³	Tube, Packing Adjustment	18842-02
15	Retainer, Needle Seal, Rear	78629-00
16 ³	O-Ring, Solvent Resistant	7554-08
17	Seal, Lip, Spring Loaded (2 Required)	10051-05
18	Spacer, Seal	78630-00
19	----	----
20	Nut, Packing	78631-00
21	Nut, Locking, Trigger Adjustment	78632-00
22	Gasket, Barrel	72360-00
23	Handle, Sub-Assembly, Conductive Plastic, REA	78641-00
24	Set Screw, Cup Point, Internal Serration, #10-32	19603-16F
25	Hook Assembly:	
	Hook / Transformer without On-Off Switch	71202-00
	Hook / Transformer with On-Off Switch	71202-01
	Kit, Switch Replacement	78086-00
	Lens, Glass, Threaded	72532-00
26	Fluid Tube / Bracket:	
	Offset (All Triggers)	20979-00
	45° (2-Finger Trigger Only)	70441-00
27	Spring, Compression	72474-01
28 ⁴	Nut, Retaining, Air Valve	78635-00

See "Parts List Bullet Definition Table".

(Continued on Next Page)

REA-70 & 70L SPRAY APPLICATORS (72074 & 75980) - PARTS LIST (Cont.) (Figure 23)

Item #	Description	Part #
29	----	----
30 ³	Rod Assembly, Air Valve	79310-00
31	Spring, Compression	17130-00
32	----	----
33	Cap, Air Valve	79317-00
34	Fan Valve Assembly (Contains Items 35 thru 41)	
	Air Spray	18851-01
	HVLP	75133-00
35	Needle, Air Spray	78788-00
	Needle, HVLP	75132-00
36	Spring, Compression	18829-00
37	Washer (2 Required)	18833-00
38	O-Ring, Solvent Proof	13076-08
39	O-Ring, Solvent Resistant	72209-05
40 ⁴	Nut, Retaining, Fan Valve	77019-00
41	Knob, Control	77018-00
42	Trigger Assembly:	
	Short, 2-Finger (All Brackets)	18871-00
	Long, 4-Finger (Offset Bracket Only)	20974-00
	Set Screw (Not Shown)	73647-02
43	Screw, Shoulder (2 Required)	6144-00
44	Nut, Hexagon	7733-07
45	Knob, Trigger Stop	77017-00
46	Spring, Compression	20977-00
47 ³	Screw, Adjustment, Trigger Stop	20976-00
48	----	----
49	----	----
50	----	----
51 ⁴	Cap, Valve Spring (2 Required)	77015-00
54	Connector, Fluid Tube	LSFI0025-20
55	Fluid Tube:	
	For 20979-00 Offset Bracket, .093" ID (5-3/4" Required)	9704-16
	For 70441-00, 45° Bracket, .093" ID (6-7/16" Required)	9704-16
56	Nut and Ferrule	3587-03
57	Nut, Jam	10553-06
58	Fluid Tube Bracket Bulkhead Fitting:	
	For 20979-00 Offset Bracket	70399-00
	For 70441-00, 45° Bracket	70442-00
69	O-Ring, Solvent Resistant (2 Required)	7554-11
70	Fitting, Air Inlet, 1/4" - 18 NPSM	18847-01
71 ¹	Hose Assembly: (Includes Items 72 thru 76)	
	Air	14614-XX*
	Fluid	14615-XX*
72 ¹	Line Hose (Bulk Hose - No Fittings):	
	Air, 5/16" I.D.	6919-XX*
	Fluid, 1/4" I.D.	77031-XX*
73	Line Fitting Assembly:	
	Air (Sold Only in Sets) (2 Required)	LSFI0027-00
	Fluid (Includes Items 74 thru 76)	14628-00
74	Ferrule, Fluid (For Fluid Hose Assembly)	7617-00
75	Nut, Fluid (For Fluid Hose Assembly)	14599-00
76	Union, Stem, Fluid (For Fluid Hose Assembly)	7623-00

See "Parts List Bullet Definition Table".

(Continued on Next Page)

REA-70 & 70L SPRAY APPLICATORS (72074 & 75980) - PARTS LIST (Cont.) (Figure 23)		
Item #	Description	Part #
77 ¹	Low Voltage Cable Assembly:	
	For Standard 9040 / MGS	78084-XX*
	For AVIATOR - All Units	78085-XX*
78	Plug Assembly:	
	For Standard 9040	76875-13
	For AVIATOR	76875-12
	For MGS	76875-11
79	O-Ring, Solvent Resistant	7554-08
80	O-Ring, Solvent Resistant	7554-12
81	Coiled Fluid Tube:	
	.093" ID	75228-11
	.250" ID	75228-12
	.125" ID	75228-13
82	Retainer, Spring, Needle Shaft	78633-00
83	Spring, Compression	78636-00
84	----	----
85	Grip, Handle, Soft-Touch	78696-00
86	----	----

PARTS LIST BULLET DEFINITION TABLE (Figure 23)	
*	XX = Specify length when ordering.
1	Dash number (-XX) reads in feet (example: -36 = 36 feet). These items are available in standard lengths of 36, 50, 75, and 100 feet. When ordering cable 76876-XX and 76878-XX, use footage for -XX.
2	See "Nozzle Selection Chart" for dash number (-XX) identification.
3	Apply dielectric grease (LSCH0009-00) when assembling as noted.
4	Apply 7969-10 (or suitable liquid or ribbon Teflon thread sealant) when assembling as noted.

NOTES

RECOMMENDED SPARE PARTS						
Description	Part Number	No. of Applicators				Notes
		1-2	3-4	5-6	7-8	
Rebuild Kit	78929-02	1	2	2	3	
Wrench, Nozzle	19749-00	2	2	4	4	
Barrel Nut	75323-00	1	2	2	3	Fits handle with 1-7/8" diameter threads
Barrel Ring	75326-00	1	2	2	3	Fits handle with 1-7/8" diameter threads
Shoulder Screw	6144-00	2	2	4	4	
Hook / Transformer	71202-XX	1	2	2	3	Replace XX with -01 for tranformer w/ switch, -00 for transformer without switch
Fluid Nozzle	4907-XX	1	2	3	4	Replace XX with 44, 45, 46, 47, or 48
Air Cap	4904-XX	1	2	3	4	Replace XX with 63, 98, or 65R
Fluid Nozzle	75600-01	1	2	3	4	For use with HVLP only
Air Cap	75601-00	1	2	3	4	For use with HVLP only
Air Cap	75756-00	1	2	3	4	For use with HVLP only
Cap Retaining Ring	73569-00	1	2	2	3	Used on caps 63, 98, 65R, 75601-00, and 75756-00 only
Low Voltage Cable (Std/MGS)	78084-XX	1	1	2	2	XX must be replaced with desired length of 36, 50, 75, or 100 feet
Low Voltage Cable (Aviator)	78085-XX	1	1	2	2	XX must be replaced with desired length of 36, 50, 75, or 100 feet
Disposable Applicator Cover	GC-100-K5	1	2	3	4	
Electrode	70430-00	2	4	6	8	

MISC. PARTS		
Item #	Description	Part #
Accessories	Loctite, Medium Strength	7969-00
	Dielectric Grease	LSCH0009-00
	Special Multi-Purpose Gun Wrench	19749-00
	Push Pull Fan Control, Air Spray	72118-00
	Disposable Applicator Cover	GC-100-K5

SERVICE KITS		
Item #	Description	Part #
Kits	Air Cap Conversion Kit, Air Spray (Contains 4904-65R Air Cap, 4907-44 Nozzle, 73569-00 Retaining Ring)	73570-01
	Air Cap Conversion Kit, Air Spray (Contains 4904-65R Air Cap, 4907-45 Nozzle, 73569-00 Retaining Ring)	73570-02
	Air Cap Conversion Kit, HVLP (Contains 75601-00 Air Cap, 75600-01 Nozzle, 73569-00 Retaining Ring)	73571-01
	HVLP Atomizer Air Cap Test Kit	75137-01
	Air Spray to HVLP Conversion Kit (Contains 75133-00 Fan Control Valve Assembly, 74963-03 White Pressure Reducer, 73569-00 Retaining Ring) With 75600-01 Fluid Nozzle & 75601-00 Air Cap With 75600-02 Fluid Nozzle & 75756-00 Air Cap With 75600-03 Fluid Nozzle & 75756-00 Air Cap	75734-01 75734-02 75734-03
	HVLP to Air Spray Conversion Kit (Contains 74963-02 Black Pressure Reducers, 18851-01 Fan Control Valve Assembly, 4904-65R Air Cap, 4907-45 Nozzle, 73569-00 Retaining Ring)	75733-00
	REA-70 Applicator Rebuild Kit (Contains the following parts): Soft Parts Kit, 78929-00 (1 Supplied) Needle Shaft, 78627-05 (1 Supplied) Tube, Packing, 18842-02 (1 Supplied) Electrode, 70430-00 (1 Supplied)	78929-02
	REA-70 Applicator Rebuild Soft Parts Kit (Contains the following parts): U-Cup Seal, 10051-05 (2 Supplied) O-Ring, Teflon, 13076-08 (1 Supplied) O-Ring, Teflon, 13076-10 (1 Supplied) O-Ring, Teflon, 13076-13 (1 Supplied) Conductive Sponge, 14061-05 (2 Supplied) Conductive Sponge, 14061-08 (1 Supplied) Cartridge Seal, 78626-00 (1 Supplied) Gasket, REA III & IV Only, 18872-00 (1 Supplied) Grease, LSCH0009-00 (1 Supplied) Gasket, REA-70 Only, 72360-00 (1 Supplied) O-Ring, 7554-08 (2 Supplied) O-Ring, 7554-10 (2 Supplied) O-Ring, 7554-11 (3 Supplied) O-Ring, 7554-12 (1 Supplied) O-Ring, 7554-28 (1 Supplied) O-Ring, 7554-33 (1 Supplied) Cup, Packing, 7723-06 (1 Supplied)	78929-00
	Gasket, Barrel Ext., REA-100A Only, 72526-00 (1 Supplied) Solvent Proof O-Ring Kit for 76875-XX Plug Assembly (Contains the following parts): O-Ring, 79001-09 (1 Supplied) O-Ring, 79001-07 (1 Supplied) O-Ring, 79001-06 (3 Supplied) Instruction Sheet, 77697-00 (1 Supplied)	77696-00

WARRANTY POLICIES

LIMITED WARRANTY

ITW Ransburg will replace or repair without charge any part and/or equipment that falls within the specified time (see below) because of faulty workmanship or material, provided that the equipment has been used and maintained in accordance with ITW Ransburg's written safety and operating instructions, and has been used under normal operating conditions. Normal wear items are excluded.

THE USE OF OTHER THAN ITW RANSBURG APPROVED PARTS, VOID ALL WARRANTIES.

SPARE PARTS: One hundred and eighty (180) days from date of purchase, except for rebuilt parts (any part number ending in "R") for which the warranty period is ninety (90) days.

EQUIPMENT: When purchased as a complete unit, (i.e., applicators, power supplies, control units, etc.), is one (1) year from date of purchase.

WRAPPING THE APPLICATOR, ASSOCIATED VALVES AND TUBING, AND SUPPORTING HARDWARE IN PLASTIC, SHRINK-WRAP, OR ANY OTHER NON-APPROVED COVERING, WILL VOID THIS WARRANTY. ITW RANSBURG'S ONLY OBLIGATION UNDER THIS WARRANTY IS TO REPLACE PARTS THAT HAVE FAILED BECAUSE OF FAULTY WORKMANSHIP OR MATERIALS. THERE ARE NO IMPLIED WARRANTIES NOR WARRANTIES OF EITHER MERCHANTABILITY OR FITNESS FOR A PARTICULAR PURPOSE. ITW RANSBURG ASSUMES NO LIABILITY FOR INJURY, DAMAGE TO PROPERTY OR FOR CONSEQUENTIAL DAMAGES FOR LOSS OF GOODWILL OR PRODUCTION OR INCOME, WHICH RESULT FROM USE OR MISUSE OF THE EQUIPMENT BY PURCHASER OR OTHERS.

EXCLUSIONS:

If, in ITW Ransburg's opinion the warranty item in question, or other items damaged by this part was improperly installed, operated or maintained, ITW Ransburg will assume no responsibility for repair or replacement of the item or items. The purchaser, therefore will assume all responsibility for any cost of repair or replacement and service related costs if applicable.

MANUAL CHANGE SUMMARY

This manual was published to replace Service Manual **AH-93-01.6**, *REA-70 and 70L Spray Applicators*, to make the following changes:

1. Added "Service Manual Price €25.00 (Euro) \$30.00 (U.S.)" to the "Front and Back Covers".
2. Added "Atex" section to service manual.
3. Removed "Appendix" section. See literature "IL-307 Technical Supplement for All Products".
4. Added "www.itwransburg.com" to the "Contact Information" on the back cover.

Service Manual Price: €25.00 (Euro)
\$30.00 (U.S.)

Manufacturing

1910 North Wayne Street
Angola, Indiana 46703-9100
Telephone: 260/665-8800
Fax: 260/665-8516

Technical/Service Assistance

Automotive Assembly and Tier I
Industrial Systems
Ransburg Guns
www.itwransburg.com

Telephone: 800/ 626-3565 Fax: 419/ 470-2040
Telephone: 800/ 233-3366 Fax: 419/ 470-2071
Telephone: 800/ 233-3366 Fax: 419/ 470-2071

Technical Support Representative will direct you to the appropriate telephone number for ordering Spare Parts.

